

PLUMBING FIXTURE SCHEDULE:

- WC-1 WATER CLOSET: AMERICAN STANDARD WALL HUNG SIPHON ELONGATED 1.28-1.6 GPF, BEMIS ELONGATED COMMERCIAL PLASTIC OPEN FRONT LESS COVER TOILET SEAT WITH STATITE CHECK HINGE, WHITE, ADA COMPLIANT. FLUSH VALVE SHALL BE SLOAN G2 81161.1 OPTIMA PLUS CLOSET FLUSH VALVE, 1.6GPF, WITH ADA COMPLIANT HANDLE.
- L-1 OVALYN UNDERCOUNTER SINK, UNIVERSAL ACCESS, WHITE, 16-3/4 IN. x 13-1/4 IN. SLOAN MODEL# EBF6504 OPTIMA BATHROOM FAUCET, 0.5 GPM. DURAPRO BATHROOM FAUCET WATER CONNECTOR SUPPLY LINE, 3/8 IN X 3/8 IN. COMPRESSION X 12 IN. LONG STAINLESS STEEL, LEAD FREE. 1-1/4 IN. STRAINER GRID. PREMIER BRASS PTRAP, CHROME, 1/2 GAUGE, 1-1/4 IN.
- UR-1 URINAL: AMERICAN STANDARD JET TOP, 1.0 GPF. VITREOUS CHINA WALL MOUNTED WITH HANGER PLATE AND CARRIER, FLUSH VALVE SHALL BE SLOAN URINAL FLUSHMETER OPTIMA PLUS 0.5 GPF OR EQUAL, CHROME PISTON FLUSH VALVE WITH ADA COMPLIANT HANDLE.
- MS-1 FIAT MODEL MSB-2424, 24 INCH X 24 INCH X 10 INCH MOLDED STONE MOP SERVICE BASIN, WITH BUMPER GUARD, STAINLESS STEEL DRAIN BODY, COMBINATION S.S. DOME STRAINER AND LINT BASKET, FIAT 830-AA, SUPPLY FITTING WITH VACUUM BREAKER, FOUR ARM HANDLES, INTEGRAL STOPS, WALL BRACE, PAIL HOOK, THREADED SPOUT, RUBBER HOSE, WALL HOOK AND MOP HANGER.
- EWC-1 ELKAY MODEL EZH20 LZS8WSLP OR EQUIVALENT. SELF CONTAINED WALL MOUNT ELECTRIC WATER COOLER. SHALL HAVE A CHILLING CAPACITY OF 8 GPH OF 50°F DRINKING WATER WITH INTEGRAL WATER FILTER AND PUSH BAR ACTIVATION AND BOTTLE FILLING STATION.

PLUMBING EQUIPMENT SCHEDULE:

- FD-A JOSAM #30000-A FLOOR DRAIN, SATIN FINISH BRONZE TOP, ADJUSTABLE STRAINER, SECURED GRATE, TRAP GUARD INSERT.
- TV ZURN MODE P6900-MV-XL UNDER-SINK GUARDIAN ASSE 1070 THERMOSTATIC TEMPERING VALVE FOR SINGLE FIXTURE APPLICATIONS. SET VALVE FOR MAXIMUM 109 DEG. F.
- WHA JOSAM #75000 SERIES WATER HAMMER ARRESTER, SIZE AND LOCATION IN ACCORDANCE W/ P.D.I. STD. WH-201, STAINLESS STEEL SHELL, ELASTOMER BELLOWS TYPE, FACTORY PRE-CHARGED WITH THREADED PLUG.
- CO JOSAM CLEANOUT
- WALL CHROME FLUSH WALL PLATE, RECESSED PLUG.
- FLOOR (UNFINISHED) - SATIN NIKALOY BRONZE TOP, RECESSED PLUG.
- FLOOR (FINISHED) - RECESSED SATIN BRONZE TOP TO RECEIVE FLOOR FINISH MATERIAL (CARPET/TILE), RECESSED PLUG.

GENERAL PLUMBING NOTES:

- MAKE PIPING CONNECTIONS AS REQUIRED TO ALL FIXTURES AND EQUIPMENT EVEN THOUGH ALL BRANCH MAINS, ELBOWS AND CONNECTIONS ARE NOT SHOWN.
- REFER TO ARCHITECTURAL WORKING DRAWING BEFORE ROUGHING-IN PLUMBING FIXTURES.
- SLOPES AND INVERT ELEVATIONS OF EXISTING SEWER SHALL BE ESTABLISHED AND VERIFIED BY CONTRACTOR BEFORE ANY PIPING IS INSTALLED IN ORDER THAT PROPER SLOPE WILL BE MAINTAINED AND NECESSARY INVERT ELEVATIONS OBTAINED.
- ALL PIPES SHALL BE COORDINATED WITH OTHER NEW AND EXISTING DUCTS, PIPES, LIGHTS, STRUCTURAL SYSTEM, CEILING SUPPORTS AND FRAMING BEFORE INSTALLATION. MINOR PIPE OFFSETS SHALL BE PROVIDED AS REQUIRED. MEASUREMENTS FOR VERTICAL CLEARANCES SHALL BE TAKEN AT THE JOB SITE BEFORE INSTALLATION OF ANY PIPING.
- WASTE PIPE BELOW FLOOR, VENT PIPING ABOVE CEILING, PIPING OFFSET FOR CLARITY.
- DOMESTIC WATER PIPING SHALL BE INSTALLED ABOVE CEILINGS UNLESS NOTED OTHERWISE. DOMESTIC WATER PIPING SHOWN IN PIPE CHASE WALLS SHALL BE INSTALLED IN CHASE SPACE, PIPING OFFSET FOR CLARITY. DOMESTIC WATER PIPING SHALL NOT BE INSTALLED IN LOCATIONS SUBJECT TO FREEZING OR SPACES EXTERIOR TO BUILDING INSULATION.
- ALL PIPING, FIXTURES AND EQUIPMENT SHALL BE INSTALLED IN ACCORDANCE WITH MANUFACTURER'S PUBLISHED INSTRUCTIONS.
- MATERIALS AND INSTALLATION SHALL COMPLY WITH LOCAL CODES, APPLICABLE PROVISIONS OF LATEST EDITION OF NATIONAL FIRE PROTECTION ASSOCIATION, LOCAL UTILITY REGULATIONS AND GOVERNMENTAL DEPARTMENTS HAVING JURISDICTION.
- WHERE PIPE CONNECTIONS ARE SHOWN CONNECTING TO EXISTING, CONTRACTOR SHALL DETERMINE EXACT LOCATIONS AND CONNECTION SIZES BY FIELD VERIFICATION PRIOR TO INSTALLATION.
- RETURN AIR PLENUM NOTE: ALL PIPING MATERIAL LOCATED IN RETURN AIR PLENUMS SHALL MEET THE REQUIREMENTS OF THE INTERNATIONAL MECHANICAL CODE, SECTION 602.2.1.
- PIPING SHALL NOT BE INSTALLED ABOVE ELECTRICAL PANELS. COORDINATE INSTALLATION OF PIPES WITH ELECTRICAL PANELS WHEN SHOWN NEAR PANELS OR OVER ELECTRICAL ROOMS.

LEGEND

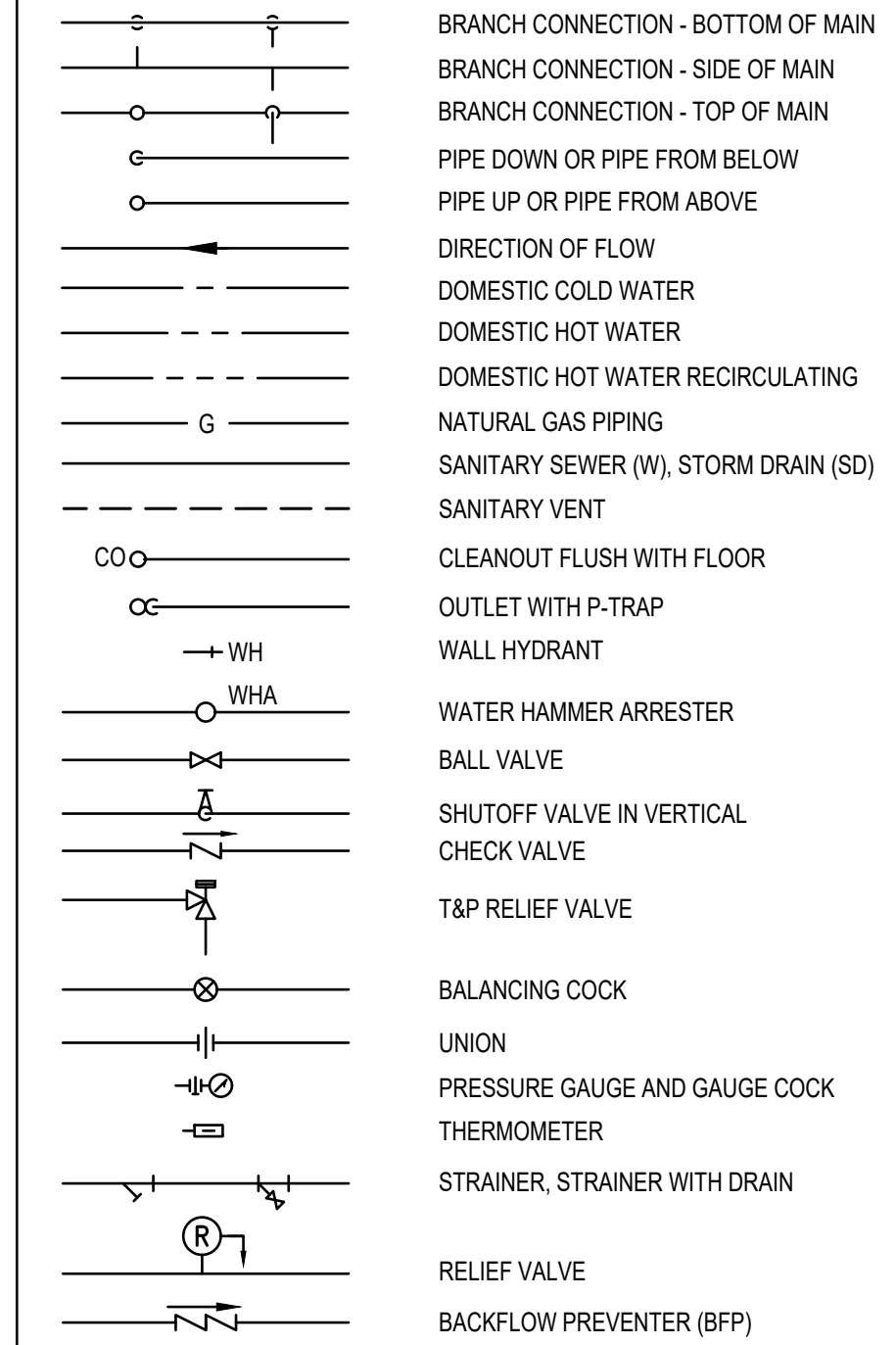

ABBREVIATIONS

AAV	AIR ADMITTANCE VALVE
ABV	ABOVE
AFF	ABOVE FINISHED FLOOR
BFF	BELOW FINISHED FLOOR
BTU	BRITISH THERMAL UNIT
BEL	BELOW
CLG	CEILING
CO	CLEANOUT
CONN	CONNECT, CONNECTION
CW	COLD WATER
CONT	CONTINUED
DN	DOWN
EA	EACH
ELEV	ELEVATION
EWC	ELECTRIC WATER COOLER
F	DEGREES FAHRENHEIT
FD	FLOOR DRAIN
FIN	FINISHED
FLR	FLOOR
FR	FROM
FT	FEET
GPH	GALLONS PER HOUR
GPM	GALLONS PER MINUTE
HB	HOSE BIBB
HC	HANDICAPPED ACCESSIBLE
HW	HOT WATER
HP	HORSEPOWER
IN	INCH, INCHES
INV	INVERT
MAX	MAXIMUM
MBH	THOUSAND BTU PER HOUR
MIN	MINIMUM
SH	SHEET
TYP	TYPICAL
V	SANITARY VENT
VTR	VENT THRU ROOF
W	SANITARY WASTE
WCO	WALL CLEANOUT
WH	WALL HYDRANT
WHA	WATER HAMMER ARRESTER

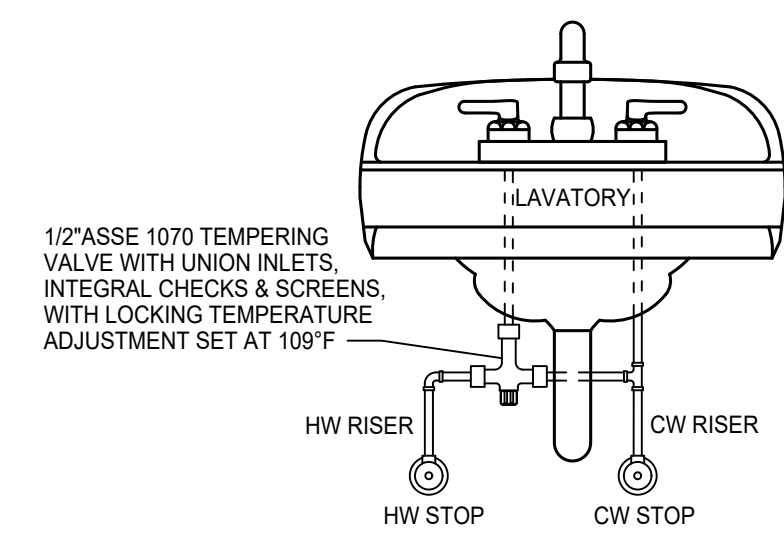

LAVATORY TEMPERING VALVE DETAIL (TV)
NO SCALE

PLUMBING FIXTURE INSTALLATION SCHEDULE

FIXTURE	MARK	MOUNTING HEIGHT, IN	COLD WATER, IN	HOT WATER, IN	VENT SIZE, IN	WASTE SIZE, IN
WATER CLOSET, WALL HUNG	WC-1	17	1/2"	-	2"	4"
PUBLIC LAVATORY, WALL HUNG	L-1	34	1/2"	1/2"	1-1/2"	2"
PUBLIC URINAL, WALL HUNG	UR-1	17	3/4"	-	1-1/2"	2"
MOP SINK	MS-1	FLOOR	1/2"	1/2"	2"	3"
ELECTRIC WATER COOLER	EWC-1	40	1/2"	-	1-1/2"	2"

- NOTES:
 1. SIZES GIVEN ARE FOR ONE FIXTURE ONLY.
 2. TRAP AND WASTE PIPE SIZES FOR FLOOR DRAINS, FLOOR SINKS, AND CLEAN OUTS SHALL BE THE SAME SIZE AS THE DRAIN SIZE INDICATED ON PLANS.

PLUMBING GENERAL NOTES, LEGEND, SCHEDULES, & DETAILS
 DATE: 05/28/2019
 COMM No: 19-01
 DRAWN BY: GTL
 CHECKED BY:
 STATE PROJECT No: MOOG, INC FACILITY AT 1213 NORTH MAIN STREET BLACKSBURG, VA 24080 MECHANICAL AND RESTROOM RENOVATIONS



5 Design, LLC
 P.O. Box 320
 Riner, VA 24149
 540-230-2619
 www.5designarchitecture.com

REVISIONS	DESCRIPTION	DATE
No. 1	OWNER REVIEW	5-29-19

STOTTSBERG ENGINEERING
 www.stottsbergeng.com
 Project #19001

P001

PLUMBING SPECIFICATIONS

1. GENERAL PROVISIONS

- A. INSTALLATION SHALL BE IN STRICT ACCORDANCE WITH THE VIRGINIA STATEWIDE BUILDING CODE INCLUDING ALL REFERENCED CODES AND STANDARDS AND IN ACCORDANCE WITH MANDATES OF THE LOCAL BUILDING OFFICIALS AND/OR LOCAL AUTHORITY HAVING JURISDICTION.
 - B. THE GENERAL ARRANGEMENT AND LOCATIONS OF PIPING, FIXTURES AND EQUIPMENT ARE INDICATED BY THE DRAWINGS AND SHALL BE INSTALLED IN ACCORDANCE THEREWITH; WITH THE EXCEPTION OF SUCH CHANGES AS MAY BE REQUIRED ON ACCOUNT OF OTHER TRADES. CONTRACTOR SHALL COORDINATE WORK WITH INSTALLATION OF OTHER SUBCONTRACTORS.
 - C. PLUMBING WORK SHALL BE COORDINATED WITH THE CONTRACTOR AS TO SCHEDULING, DIMENSIONING AND LOCATION OF EQUIPMENT.
 - D. MAJOR ITEMS ARE SHOWN ON THE PROJECT PLANS. CONTRACTOR SHALL BE RESPONSIBLE FOR ALL INCIDENTAL ITEMS REQUIRED TO PROVIDE A COMPLETE AND FUNCTIONAL SYSTEM.
 - E. ALL PIPING SYSTEMS SHALL EXTEND 5 FEET BEYOND THE BUILDING LINE UNLESS INDICATED OTHERWISE. REFER TO CIVIL DRAWINGS FOR PIPING OUTSIDE THIS AREA.
 - F. TRADE NAMES AND CATALOG NUMBERS SHALL BE INTERPRETED AS ESTABLISHING A GENERAL DESIGN AND STANDARD OF QUALITY AND SHALL NOT BE CONSTRUED AS LIMITING COMPETITION. UNLESS STATED OTHERWISE, THE CONTRACTOR MAY USE ANY ARTICLE WHICH, IN HIS JUDGEMENT, AND WITH WRITTEN COMMENT FROM THE ARCHITECT/ENGINEER INDICATING NO OBJECTION, IS EQUAL OR SUPERIOR TO THAT SPECIFIED. DRAWINGS SHOWING CHANGES OR REVISIONS REQUIRED BY THE SUBSTITUTION FOR SPECIFIED ITEMS SHALL BE SUBMITTED WITH THE SHOP DRAWING DATA, AND THE COSTS OF ALL SUCH CHANGES SHALL BE BORNE BY THE CONTRACTOR.
 - G. SIMILAR ITEMS SHALL BE PROVIDED BY A SINGLE MANUFACTURER.
 - H. ALL REQUIRED WALL OR FLOOR OPENINGS SHALL BE COORDINATED WITH THE CONTRACTOR.
 - I. ALL PIPING SHALL BE ABOVE CEILING UNLESS INDICATED OTHERWISE.
 - J. ALL EQUIPMENT SHALL BE WIPED CLEAN, REMOVING ALL TRACES OF OIL, DIRT, OR PAINT SPOTS.
 - K. PROVIDE SUPPORTS TO RIGIDLY ATTACH ALL EQUIPMENT, APPURTENANCES AND PIPE AS REQUIRED FOR SUPPORT. PRIOR TO INSTALLATION OF HANGERS AND INSERTS, THE CONTRACTOR SHALL COORDINATE LOCATIONS AND REQUIREMENTS TO MINIMIZE CONFLICTS WITH OTHER BUILDING SYSTEMS. INSTALLATION OF PIPE HANGERS AND SUPPORTS SHALL BE IN STRICT ACCORDANCE WITH MSS SP-58, 69 AND 89.
 - L. CONTRACTOR SHALL MAKE FINAL CONNECTIONS TO ALL EQUIPMENT INDICATED TO BE FURNISHED BY OTHERS.
- 2. SUBMISSION OF SHOP DRAWINGS, PRODUCT DATA, SAMPLES AND PROJECT INFORMATION**
- A. SHOP DRAWINGS SHALL BE SUBMITTED FOR THE FOLLOWING ITEMS:
 - (1) CLEANOUTS
 - (2) FLOOR DRAINS
 - (3) BALL VALVES
 - (4) CHECK VALVES
 - (5) SHOCK ABSORBERS
 - (6) WATER HEATERS
 - (7) PLUMBING FIXTURES
 - (8) ALL ITEMS LISTED ON PLUMBING EQUIPMENT SCHEDULE.
 - B. IDENTIFY ALL PLUMBING SHOP DRAWINGS, PRODUCT DATA AND SAMPLES WITH THE NAME OF THE PROJECT. CLEARLY MARK THE SPECIFIC ITEMS INTENDED FOR USE. SUBMIT ALL RELATED ITEMS AT ONE TIME.
 - C. PRIOR TO SUBSTANTIAL COMPLETION OF THE PROJECT, SUBMIT THE FOLLOWING INFORMATION FOR REVIEW AND APPROVAL.
 - (1) "AS BUILT" DRAWINGS.
- 3. GUARANTEE: ALL MATERIALS AND WORKMANSHIP SHALL BE GUARANTEED TO BE FREE FROM DEFECTS FOR A PERIOD OF ONE (1) YEAR FROM DATE OF ACCEPTANCE AND CONTRACTOR SHALL MAKE GOOD, WITHOUT ADDITIONAL COST TO THE OWNER, ANY DEFECTS WHICH MAY APPEAR WITHIN THAT PERIOD. MANUFACTURER'S WARRANTIES EXTENDING BEYOND ONE YEAR SHALL BE PROCESSED AND TURNED OVER TO THE OWNER.**
- 4. "AS BUILT" DRAWINGS: CONTRACTOR SHALL KEEP AN ACCURATE RECORD OF THE LOCATION OF ALL CONCEALED PIPING, VALVES, CONTROLS, ETC., BOTH INTERIOR AND EXTERIOR. ON COMPLETION OF THE WORK, ONE PRINT EACH OF THE CONTRACT DRAWINGS WHICH ARE APPLICABLE SHALL BE NEATLY AND CLEARLY MARKED IN COLOR TO SHOW ALL VARIATIONS BETWEEN THE WORK ACTUALLY PROVIDED AND THAT INDICATED ON THE CONTRACT DRAWINGS.**
- 5. ACCESS DOORS: ACCESS DOORS SHALL BE PROVIDED FOR ALL CONCEALED VALVES, CONTROLS, AND ANY OTHER EQUIPMENT OR MATERIALS REQUIRING INSPECTION OR MAINTENANCE. ACCESS DOORS SHALL BE FURNISHED FOR FLOORS, WALLS AND CEILINGS. OF ADEQUATE SIZE SO THAT CONCEALED ITEMS WILL BE READILY ACCESSIBLE FOR SERVICING OR FOR REMOVAL AND REPLACEMENT IF NECESSARY.**
- 6. PIPING SPECIALTIES**
- A. PIPE ESCUTCHEONS: INSTALL PIPE ESCUTCHEONS ON EACH PIPE PENETRATION THRU FLOORS, WALLS PARTITIONS, AND CEILINGS WHERE PENETRATION IS EXPOSED TO VIEW AND ON EXTERIOR OF BUILDING. SECURE ESCUTCHEON TO PIPE OR INSULATION SO ESCUTCHEON COVERS PENETRATION HOLE, AND IS FLUSH WITH ADJOINING SURFACE. PROVIDE SHEET STEEL ESCUTCHEONS, SOLID OR SPLIT HINGED. FOR AREAS WHERE WATER AND CONDENSATION CAN BE EXPECTED TO ACCUMULATE, PROVIDE CAST BRASS OR SHEET BRASS ESCUTCHEONS, SOLID OR SPLIT HINGED.

- B. PIPE SLEEVES: INSTALL PIPE SLEEVES WHERE PIPING PASSES THROUGH WALLS, FLOORS, CEILINGS, AND ROOFS. DO NOT INSTALL SLEEVES THROUGH STRUCTURAL MEMBERS OF WORK, EXCEPT AS DETAILED ON DRAWINGS, OR AS REVIEWED BY ARCHITECT/ENGINEER. SIZE SLEEVES SO THAT PIPING AND INSULATION (IF ANY) WILL HAVE FREE MOVEMENT IN SLEEVE, INCLUDING ALLOWANCE FOR THERMAL EXPANSION; BUT NOT LESS THAN 2 PIPE SIZES LARGER THAN PIPING RUN. INSTALL LENGTH OF SLEEVE EQUAL TO THICKNESS OF CONSTRUCTION PENETRATED, AND FINISH FLUSH TO SURFACE, EXCEPT FLOOR SLEEVES. EXTEND FLOOR SLEEVES 1/4 INCH ABOVE LEVEL FLOOR FINISH, AND 3/4 INCH ABOVE FLOOR FINISH SLOPED TO DRAIN. PROVIDE TEMPORARY SUPPORT OF SLEEVES DURING PLACEMENT OF CONCRETE AND OTHER WORK AROUND SLEEVES, AND PROVIDE TEMPORARY CLOSURE TO PREVENT CONCRETE AND OTHER MATERIALS FROM ENTERING SLEEVES.

- 7. INSULATION**
- A. FLAME/SMOKE RATINGS: PROVIDE COMPOSITE PLUMBING INSULATION (INSULATION, JACKETS, COVERINGS, SEALERS, MASTICS AND ADHESIVES) WITH FLAME-SPREAD RATING OF 25 OR LESS, AND SMOKE-DEVELOPED RATING OF 50 OR LESS, AS TESTED BY ASTM E84 METHOD. INSULATION SHALL BE LABELED BY THE MANUFACTURER. THE LABEL SHALL INDICATE THE INSULATING VALUE, FLAME SPREAD AND SMOKE-DEVELOPED RATING.

- B. SUBMITTALS: SUBMIT MANUFACTURER'S SPECIFICATIONS AND INSTALLATION INSTRUCTIONS FOR EACH TYPE OF PLUMBING INSULATION. SUBMIT SCHEDULE SHOWING MANUFACTURER'S PRODUCT NUMBER, THICKNESS, AND FURNISHED ACCESSORIES FOR EACH PLUMBING SYSTEM REQUIRING INSULATION.

- C. INSTALLATION: INSULATION SHALL BE APPLIED IN ACCORDANCE WITH MANUFACTURER'S RECOMMENDATIONS USING ONLY ADHESIVES, MASTICS AND PLUMBING FASTENERS APPROVED BY THE INSULATION MANUFACTURER. INSULATION SHALL NOT BE APPLIED UNTIL AFTER THE EQUIPMENT HAS BEEN TESTED WITH RESULTS ACCEPTABLE TO THE ARCHITECT/ENGINEER. INSULATION WITH A VAPOR BARRIER JACKET SHALL BE APPLIED WITH A CONTINUOUS, UNBROKEN VAPOR SEAL AND ALL JOINTS SHALL BE SEALED WITH A VAPOR BARRIER ADHESIVE UNLESS OTHERWISE INDICATED. STAPLES, STICK CLIPS AND HANGERS SHALL BE VAPOR SEALED WHERE THEY PUNCTURE VAPOR BARRIER JACKETS.

- D. MATERIALS:
 - (1) GLASS FIBER PIPE INSULATION: HEAVY DENSITY PREFORMED PIPE INSULATION WITH OPERATING TEMPERATURE RANGE OF -60 DEGREES F TO 350 DEGREES F, THERMAL CONDUCTIVITY "K"=0.24 BTU-IN/HOUR-SF-DEG F AT 100 DEGREES F. FACTORY APPLIED JACKET (ASJ) SHALL CONSIST OF WHITE KRAFT PAPER BONDED TO ALUMINUM FOIL AND REINFORCED WITH GLASS FIBER YARN. EQUAL TO OWENS-CORNING ASJ.
 - (2) CELLULAR FOAM PIPE INSULATION: TUBULAR, FLEXIBLE, FIRE RESISTANT INSULATION WITH OPERATING TEMPERATURE RANGE OF -40 DEGREES F TO 220 DEGREES F, THERMAL CONDUCTIVITY "K"=0.27 BTU-IN/HOUR-SF-DEG F AT 75 DEGREES F. NO JACKET REQUIRED. EQUAL TO ARMSTRONG ARMAFLEX AP.
 - (3) POLYETHYLENE PIPE INSULATION: INSULATION MATERIALS CORPORATION OF AMERICA (MCOA), FLEXIBLE CLOSED CELL POLYETHYLENE TUBING, ASTM G534, "K"=0.24 AT 75 DEGREES F. SERVICE TEMPERATURE -110F TO 210F. NO JACKET REQUIRED.

- E. PIPE INSULATION
 - (1) INSULATION OMITTED: OMIT INSULATION ON EXPOSED PLUMBING FIXTURE RUNOUTS FROM FACES OF WALL OR FLOOR TO FIXTURE; ON UNIONS, FLANGES, STRAINERS, FLEXIBLE CONNECTIONS, AND EXPANSION JOINTS.
 - (2) COVER VALVES, FITTINGS AND SIMILAR ITEMS IN EACH PIPING SYSTEM WITH EQUIVALENT THICKNESS AND COMPOSITION OF INSULATION AS APPLIED TO ADJOINING PIPE RUN.
 - (3) EXTEND PIPING INSULATION WITHOUT INTERRUPTION THROUGH WALLS, FLOORS AND SIMILAR PIPING PENETRATIONS, EXCEPT WHERE OTHERWISE INDICATED.
 - (4) INSTALL PROTECTIVE METAL SHIELDS AND INSULATED INSERTS WHEREVER NEEDED TO PREVENT COMPRESSION OF INSULATION.
 - (5) PIPE HANGER INSULATION INSERTS: BUTT PIPE INSULATION AGAINST PIPE INSULATION INSERTS. FOR HOT PIPES, APPLY 3 INCH WIDE VAPOR BARRIER TAPE OR BAND OVER THE BUTT JOINTS. FOR COLD PIPING APPLY WET COAT OF VAPOR BARRIER LAP CEMENT ON BUTT JOINTS AND SEAL JOINTS WITH 3 INCH WIDE VAPOR BARRIER TAPE OR BAND.
 - (6) DOMESTIC WATER PIPING, ABOVE GROUND: PIPING SHALL BE INSULATED WITH GLASS FIBER PIPE INSULATION. CELLULAR FOAM OR POLYETHYLENE PIPE INSULATION MAY BE USED ON PIPE SIZES 1 INCH AND SMALLER. VAPOR SEAL IS NOT REQUIRED ON HOT WATER PIPING.

MATERIAL HANDLED	PIPE SIZE	INSULATION THICKNESS
COLD WATER	ALL SIZES	1/2"
HOT WATER AND HOT WATER RECIRCULATING	ALL SIZES	1/2"

8. PLUMBING PIPING

- A. DOMESTIC WATER PIPING ABOVE GROUND
 - COPPER TUBE AND FITTINGS ASTM B88, TYPE L HARD DRAWN
 - FITTINGS: WROUGHT COPPER, ASME B16.22 OR CAST COPPER ALLOY ASME B16.18.
 - JOINTS: ABV GROUND, ASTM B32 LEAD FREE SOLDER, ASTM B813 LEAD FREE FLUX.

- B. STORM, SOIL, WASTE AND VENT PIPING BELOW GRADE

- SIZE: 4 INCHES AND SMALLER
- PIPE: SCH. 40 PVC-DWV ASTM D-2665
- FITTINGS: PVC SOCKET FITTINGS (DWV)
- JOINTS: SOLVENT CEMENT JOINTS

- C. STORM, SOIL, WASTE AND VENT PIPING ABOVE GRADE

- SIZE: 4 INCHES AND SMALLER
- HUBLESS ASTM C-564
- FITTINGS: HUBLESS CAST IRON
- JOINTS: NEOPRENE SLEEVES AND STAINLESS STEEL BANDS

- D. ALL PIPE OF THE SAME SIZE SHALL BE THE SAME MATERIAL.

- E. SLOPE ALL DRAIN LINES 1/4 INCH PER FOOT MINIMUM FOR SIZES LESS THAN 4 INCHES; SLOPE 1/8 INCH PER FOOT FOR SIZES 4 INCHES AND LARGER.

- F. SOIL, WASTE AND VENT PIPING LOCATED BELOW GRADE SHALL BE MINIMUM 2 INCH SIZE.

- G. VENTS SHALL EXTEND 12 INCHES ABOVE THE ROOF. ROOF FLASHING SHALL BE COORDINATED WITH BY THE CONTRACTOR.

- H. CONTRACTOR SHALL BE RESPONSIBLE FOR ALL BELOW GRADE WORK IN ACCORDANCE WITH THE FOLLOWING:
 - (1) TRENCHES SHALL BE GRADED TO UNIFORM PITCH AND SHALL BE NO WIDER THAN NECESSARY AND FREE FROM LOOSE EARTH.
 - (2) CLEAN BACKFILL SHALL BE USED AND THOROUGHLY TAMPED IN LAYERS NOT EXCEEDING 6 INCHES TO A MINIMUM DEPTH OF 1 FOOT ABOVE PIPE.
 - (3) COMPACTED BACKFILL SHALL BE USED FOR ENTIRE DEPTH OF EXCAVATION UNDER SLAB ON GRADE CONSTRUCTION.

- I. DOMESTIC HOT AND COLD WATER PIPING SHALL BE 1/2 INCH SIZE UNLESS INDICATED OTHERWISE.

9. NATURAL GAS SYSTEMS

- A. GAS SERVICE PIPING:
 - ALL SIZES: SCHEDULE 40 BLACK STEEL PIPE, ASTM A120/A53-CW OR ASTM/A53 GRADE B (WELDED OR SEAMLESS); WROUGHT STEEL BUTTWELDING FITTINGS.

- B. GAS COCKS:
 - GAS COCKS 2 INCHES AND SMALLER: 150 PSI NON-SHOCK WOG, BRONZE STRAIGHTWAY COCK, FLAT OR SQUARE HEAD, THREADED ENDS.

- C. ALL GAS PIPING EQUIPMENT CONNECTIONS SHALL BE PROVIDED WITH A 6 INCH DIRT TRAP, UNION AND GAS COCK SHUT OFF.

- D. ALL JOINTS SHALL BE SEALED WITH CHEMICALLY RESISTANT SEALER APPLIED TO MALE THREADS OF PIPE CONNECTION.

- E. GAS PIPING SHALL BE INSTALLED WITH A 1/64 INCH PER FOOT DOWNWARD SLOPE IN DIRECTION OF FLOW.

10. PLUMBING PUMPS

- A. UL COMPLIANCE: DESIGN, MANUFACTURE, AND INSTALL PLUMBING PUMPS IN ACCORDANCE WITH UL 778 "MOTOR OPERATED WATER PUMPS".

- B. UL AND NEMA COMPLIANCE: PROVIDE ELECTRIC MOTORS AND COMPONENTS WHICH ARE LISTED AND LABELED BY UNDERWRITERS LABORATORIES AND COMPLY WITH NEMA STANDARDS.

- C. SSPMA COMPLIANCE: TEST AND RATE SUMP AND SEWAGE PUMPS IN ACCORDANCE WITH SUMP AND SEWAGE PUMP MANUFACTURERS ASSOCIATION (SSPMA) AND PROVIDE CERTIFIED RATING SEAL.

- D. PUMP CAPACITY CURVES SHALL SLOPE UP TO MAXIMUM HEAD SHUT OFF. SELECT PUMPS NEAR MID-RANGE OF CURVE AS CLOSE TO MAXIMUM EFFICIENCY AS POSSIBLE.

- E. PUMP HEAD SHALL BE INCREASED IF NECESSARY TO PROVIDE SPECIFIED FLOW RATE THROUGH EQUIPMENT APPROVED FOR THIS PROJECT.

11. CLEANOUTS

- A. CLEANOUTS SHALL BE THE SAME SIZE AS LINE SERVED, BUT NOT LARGER THAN 4 INCHES, AND SHALL BE PROVIDED AT THE BASE OF EACH SOIL AND WASTE STACK, AT ALL POINTS WHERE DIRECTION CHANGE IS MORE THAN 45 DEGREES, AT MINIMUM INTERVALS OF 50 FEET FOR 4 INCH AND SMALLER PIPING, AT MINIMUM INTERVALS OF 100 FEET FOR PIPING LARGER THAN 4 INCHES, AS REQUIRED BY CODE AND AS INDICATED ON THE DRAWINGS. COVERS SHALL BE SET FLUSH WITH FLOOR OR WALL.

12. FLOOR DRAINS

- A. PROVIDE FLOOR DRAINS OF SIZE AND TYPE AS INDICATED ON DRAWINGS. ALL DRAINS CONNECTING TO SANITARY SEWER SYSTEM SHALL BE FURNISHED WITH TRAP SEAL AND P-TRAP. DRAINS SHALL HAVE OUTLET COMPATIBLE WITH PIPING SYSTEM TO WHICH IT IS CONNECTED.

13. PLUMBING VALVES

- A. PROVIDE SHUT-OFF VALVE AND UNION OR EQUIVALENT AT EACH HOT AND COLD WATER EQUIPMENT CONNECTION. PROVIDE SHUT-OFF VALVE ON EACH BRANCH OR RISER THAT SERVES TWO OR MORE PLUMBING FIXTURES.

- B. GATE VALVES 2-1/2 INCHES AND SMALLER: ALL BRONZE, RISING STEM, SOLID WEDGE DISC. STOCKHAM B-100 OR B-108.

- C. GLOBE VALVES: ALL BRONZE, RENEWABLE COMPOSITION DISC. STOCKHAM B-16 OR B-14-T.

- D. CHECK VALVES IN HORIZONTAL PIPES:
 - (1) 2 INCHES AND SMALLER: ALL BRONZE, REGRINDING BRONZE DISC, HORIZONTAL SWING, Y-PATTERN. STOCKHAM B-3190R B-309.

- E. CHECK VALVES IN VERTICAL PIPES AND PUMP DISCHARGE: SILENT CHECK VALVE WITH SEMI-STEEL BODY, BRONZE TRIM AND STAINLESS STEEL SPRING. METRAFLEX 700 SERIES.

- F. BALL VALVES MAY BE USED IN LIEU OF GATE VALVES 2 INCHES AND SMALLER. BALL VALVES SHALL HAVE BRONZE BODY, BRONZE BALL AND TFE SEATS AND SEALS. STOCKHAM S-216BRR1 OR S-216BRRS.

14. WATER HEATERS

- A. NSF LABELS: PROVIDE WATER HEATERS WHICH HAVE BEEN LISTED AND LABELED BY THE NATIONAL SANITATION FOUNDATION.

- B. UL AND NEMA COMPLIANCE: PROVIDE ELECTRIC MOTORS AND ELECTRICAL COMPONENTS REQUIRED AS PART OF PLUMBING EQUIPMENT, WHICH HAVE BEEN LISTED AND LABELED BY UNDERWRITERS LABORATORIES AND COMPLY WITH NEMA STANDARDS.

- C. NEC COMPLIANCE: COMPLY WITH NATIONAL ELECTRICAL CODE (ANSI/NFPA 70) AS APPLICABLE TO INSTALLATION AND ELECTRICAL CONNECTIONS OF ANCILLARY ELECTRICAL COMPONENTS OF PLUMBING EQUIPMENT.

- D. ASHRAE COMPLIANCE: WATER HEATERS SHALL COMPLY WITH ASHRAE STANDARD 90.

- E. WATER HEATERS SHALL BE FURNISHED WITH ASME RATED TEMPERATURE AND PRESSURE RELIEF VALVE WITH TEST LEVER.

13. PLUMBING FIXTURES

- A. CODES AND STANDARDS: COMPLY WITH APPLICABLE PORTIONS OF NATIONAL STANDARD PLUMBING CODE AND THE VIRGINIA STATEWIDE BUILDING CODE, PERTAINING TO MATERIALS AND INSTALLATION OF PLUMBING FIXTURES.

- (1) ANSI STANDARDS: COMPLY WITH APPLICABLE ANSI STANDARDS PERTAINING TO PLUMBING FIXTURES AND SYSTEMS.

- (2) ANSI AND ADA COMPLIANCE: CONSTRUCT AND INSTALL BARRIER FREE PLUMBING FIXTURES IN ACCORDANCE WITH ANSI STANDARD A117.1 "SPECIFICATIONS FOR MAKING BUILDINGS AND FACILITIES ACCESSIBLE TO AND USABLE BY PHYSICALLY HANDICAPPED PEOPLE" AND WITH THE "AMERICANS WITH DISABILITIES ACT GUIDELINES".

- B. ALL EXPOSED FIXTURE SUPPLIES AND WASTE LINES SHALL BE CHROME PLATED. NO EXPOSED COPPER, PVC AND/OR CAST IRON PIPING IS ALLOWED. UTILIZE CHROME NIPPLES AS REQUIRED FOR DOMESTIC ROUGH-IN.

- C. PLUMBING FIXTURES SHALL BE POSITIVELY VENTED AND TRAPPED IN ACCORDANCE WITH THE VIRGINIA STATEWIDE BUILDING CODE, LATEST EDITION. WET VENTING IS ALLOWED IF WASTE PIPING IS OVERSIZED AND IN ACCORDANCE WITH CODE PROVISIONS. LOCATION OF VENT SHALL NOT EXCEED MAXIMUM DISTANCES TO THE TRAP AS ESTABLISHED WITHIN THE CODE.

15. CLEANING AND TESTING

- A. ALL WATER PIPING, VALVES, ETC. SHALL BE THOROUGHLY FLUSHED OF FOREIGN MATTER AND TESTED FOR LEAKS IN ACCORDANCE WITH THE VIRGINIA STATEWIDE BUILDING CODE, LATEST EDITION. ANY LEAKAGE SHALL BE REPAIRED. DISINFECT DOMESTIC WATER PIPING INCLUDING WATER SERVICE PIPING IN ACCORDANCE WITH AWWA C601.

- B. ALL DRAIN, WASTE AND VENT PIPING SHALL BE TESTED FOR LEAKS IN ACCORDANCE WITH THE VIRGINIA STATEWIDE BUILDING CODE, LATEST EDITION. NO VISIBLE DROP IN WATER LEVEL WILL BE ACCEPTABLE.

END OF SPECIFICATIONS

DATE:	05/28/2019
COMM No.:	19-01
DRAWN BY:	GTL
CHECKED BY:	
STATE PROJECT No.:	

PLUMBING SPECIFICATIONS

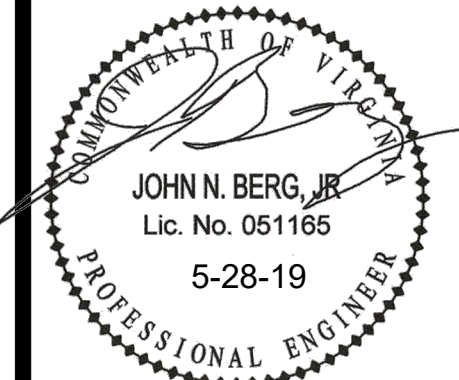

5 Design, LLC
 P.O. Box 320
 Riner, VA 24149
 540-230-2619
 www.5designarchitecture.com

REVISIONS	DATE	DESCRIPTION
No.	5-29-19	OWNER REVIEW

STOTTSBERG ENGINEERING
 www.stottsbergeng.com
 Project #19001

P002

**ENLARGED PLANS OF PLUMBING
 DEMOLITION AND NEW WORK**

MOOG, INC FACILITY AT 1213 NORTH MAIN STREET BLACKSBURG, VA 24060
 MECHANICAL AND RESTROOM RENOVATIONS



5 Design, LLC
 P.O. Box 320
 Riner, VA 24149
 540-230-2619
 www.5designarchitecture.com

REVISIONS	DESCRIPTION	DATE
No.	△	△
	△	△
	△	△

P100

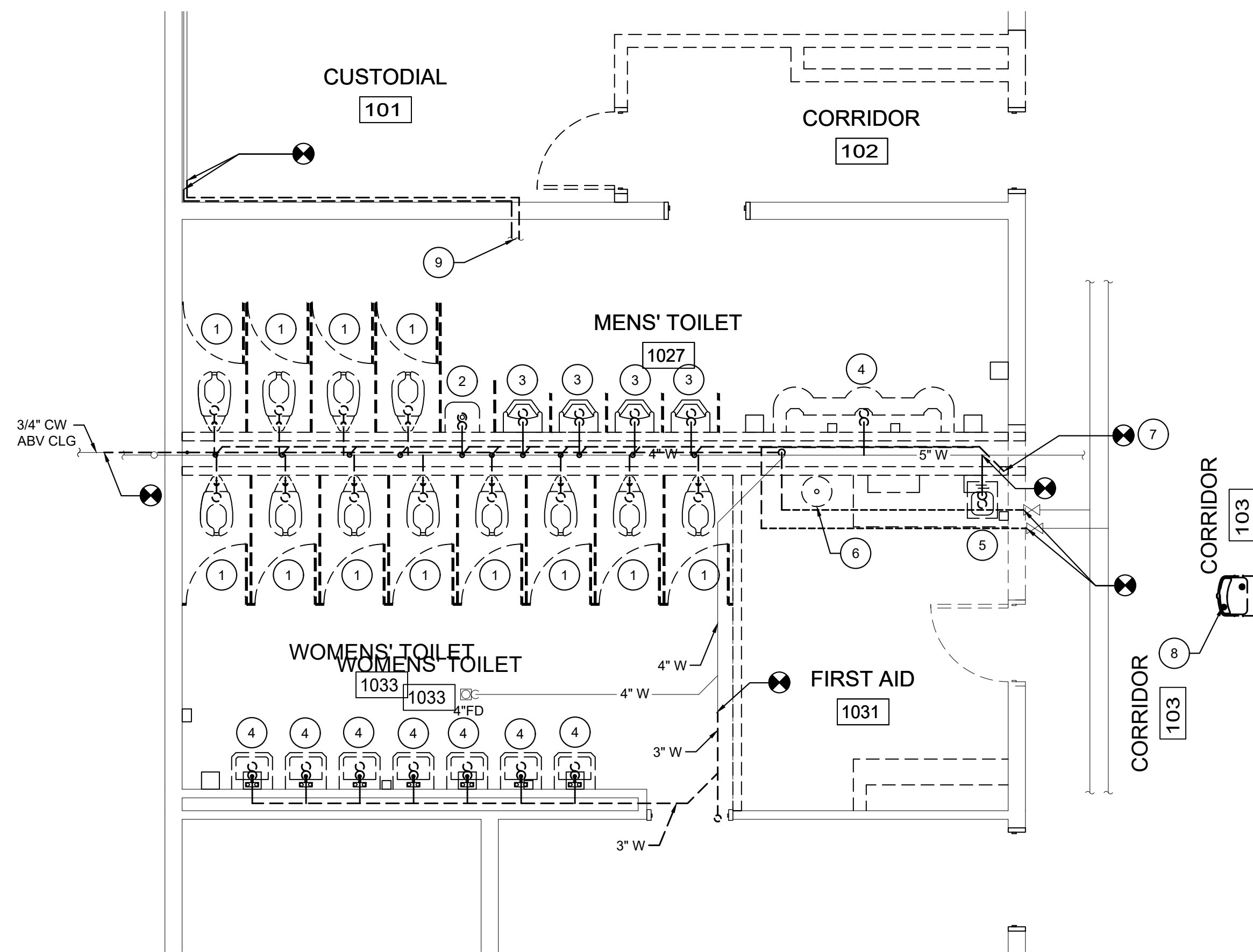

ENLARGED PLAN OF DEMOLITION

1/4" = 1'-0"



GENERAL DEMOLITION NOTES:

- CONTRACTOR SHALL FIELD VERIFY ALL EXISTING PLUMBING PIPING SIZES AND LOCATIONS PRIOR TO BIDDING.
- FOR FIXTURES BEING REMOVED, ALL ASSOCIATED BRANCH PIPING SHALL BE REMOVED BACK TO ASSOCIATED MAIN AND CAPPED UNLESS INDICATED OTHERWISE ON NEW WORK PLANS.

DEMOLITION KEYED NOTES:

- EXISTING WATER CLOSET TO BE REMOVED IN ITS ENTIRETY.
- EXISTING SERVICE SINK TO BE REMOVED IN ITS ENTIRETY.
- EXISTING URINAL TO BE REMOVED IN ITS ENTIRETY.
- EXISTING LAVATORY TO BE REMOVED IN ITS ENTIRETY.
- EXISTING SINK TO BE REMOVED IN ITS ENTIRETY.
- EXISTING FLOOR DRAIN TO BE REMOVED IN ITS ENTIRETY. REMOVE BRANCH SANITARY PIPING BELOW GRADE BACK TO MAIN AND CAP.
- DEMO VENT PIPING BACK TO 4" VENT STACK THRU ROOF.
- EXISTING ELECTRIC WATER COOLER TO BE REMOVED IN ITS ENTIRETY. REMOVE SUPPLY AND WASTE PIPING BACK BEHIND FINISHED SURFACE AND CAP.
- EXISTING CONDENSATE DRAIN LINES TO SINK DRAIN TO BE REMOVED BACK TO MECHANICAL ROOM AND CAP.

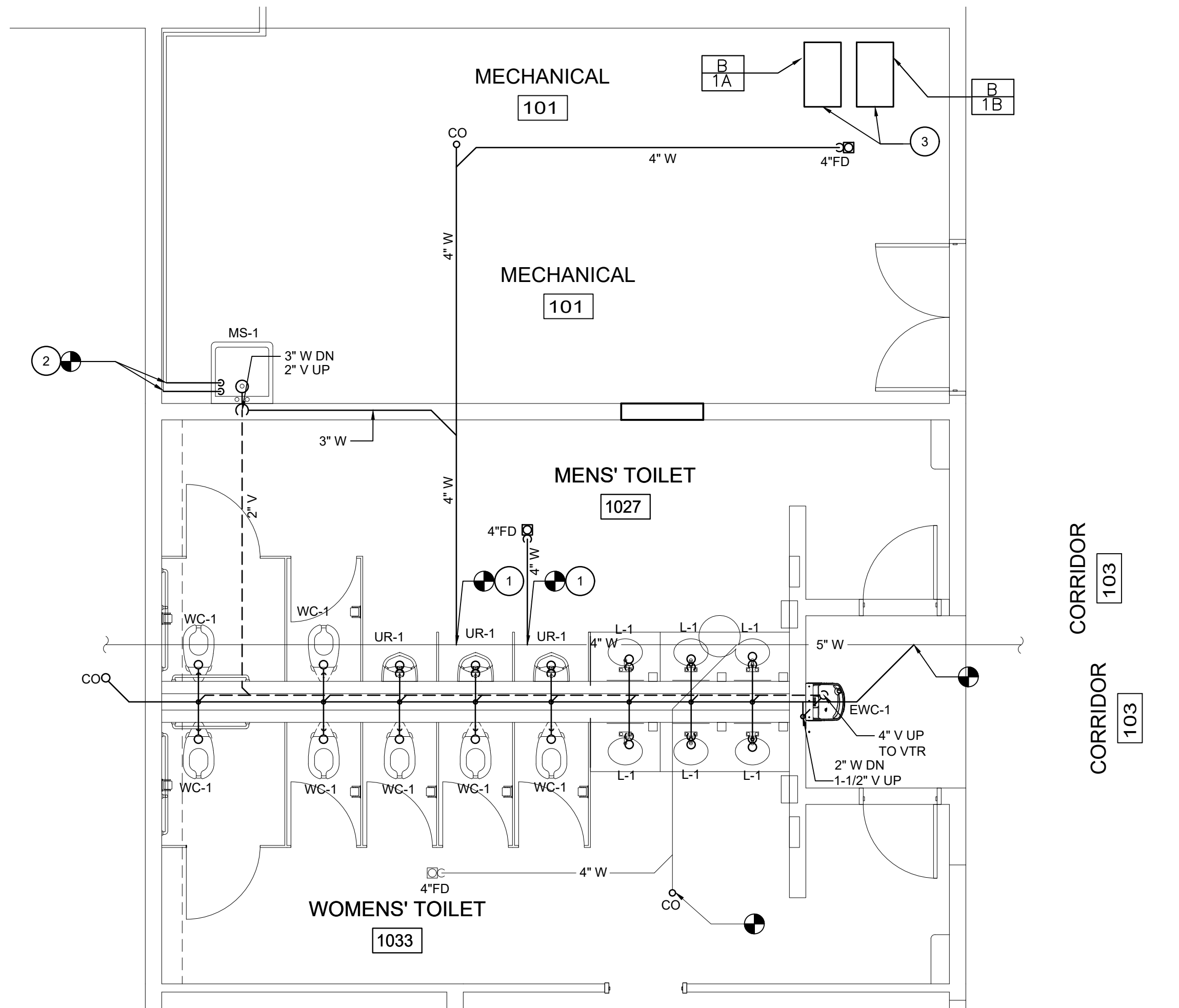

ENLARGED PLAN OF NEW WORK - W&V

1/4" = 1'-0"

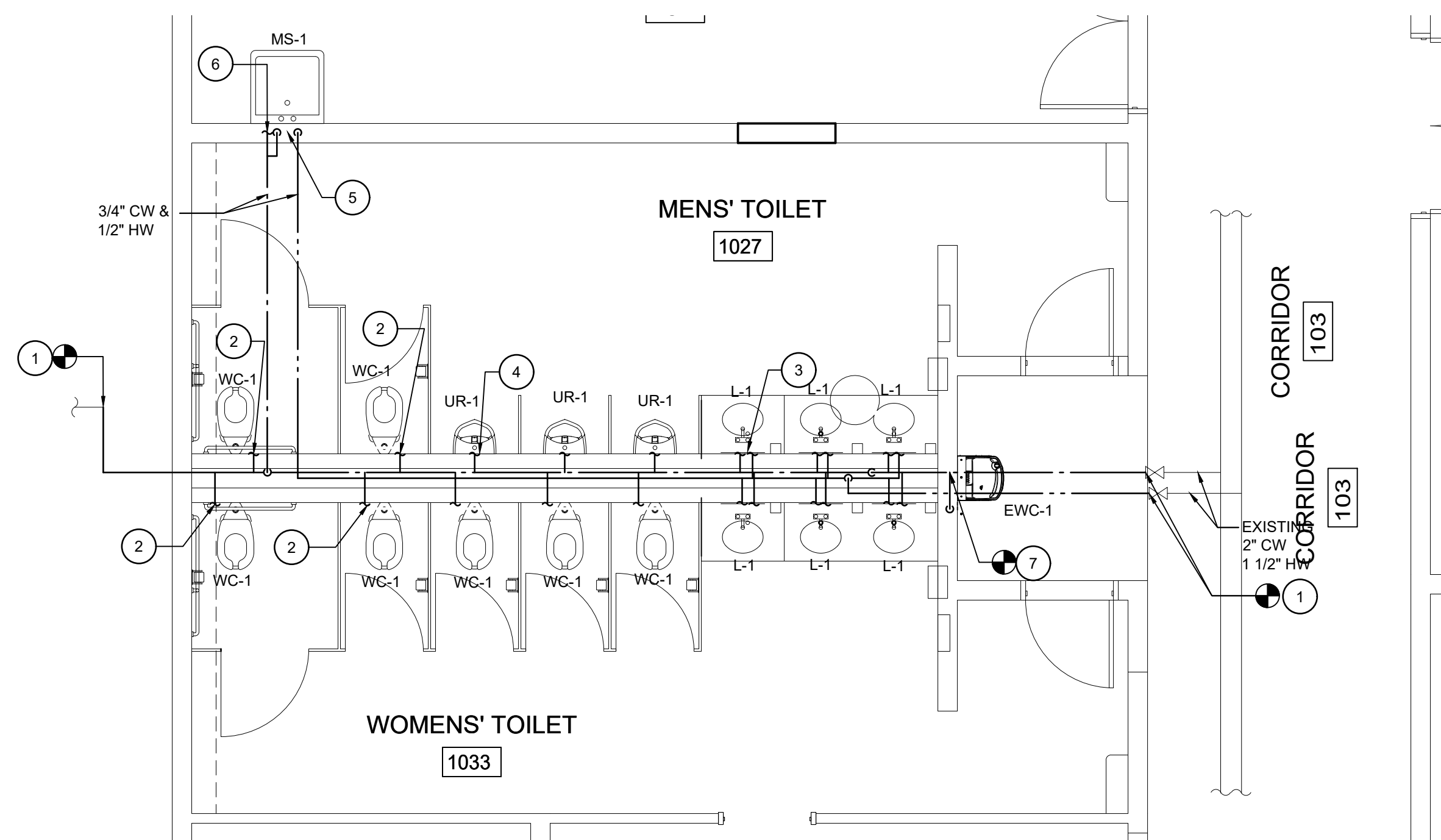
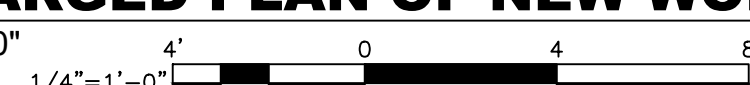

ENLARGED PLAN OF NEW WORK - WATER

1/4" = 1'-0"



NEW WORK KEYED NOTES - W&V:

- CONNECT TO EXISTING SANITARY WASTE PIPING BELOW FLOOR.
- CONNECT TO EXISTING DRAINS AND ROUTE TO MS-1.
- ROUTE DRAIN FROM BOILERS TO FLOOR DRAIN.

NEW WORK KEYED NOTES - WATER:

- CONNECT TO EXISTING SUPPLY PIPING ABOVE CEILING.
- 1" DN TO WATER CLOSET. PROVIDE WATER HAMMER ARRESTOR. (TYPICAL)
- 1/2" HW & CW DN TO LAV. (TYPICAL)
- 3/4" CW DN TO URINAL. (TYPICAL)
- 1/2" HW & CW DN TO MOP SINK.
- 3/4" CW TO MIXING SYSTEM AT MS-1.
- CONNECT TO EXISTING SUPPLY PIPING ABOVE CEILING. PROVIDE 1/2" CW DN TO WATER COOLER.

**STOTTSBERG
 ENGINEERING**

www.stottsberg.com
 Project #19001



MEZZANINE
300

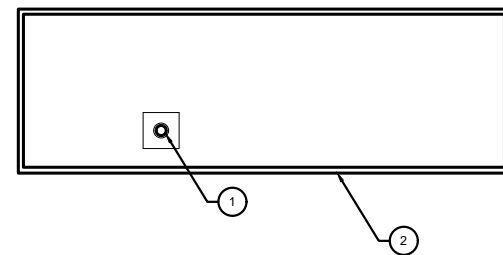

PARTIAL PLUMBING ROOF PLAN

1/8" = 1'-0"



NEW WORK KEYED NOTES

1. RE-LOCATE EXISTING ROOF DRAIN TO OUTSIDE OF NEW ROOFTOP UNIT FOOT PRINT.
2. NEW ROOFTOP UNIT IS SHOWN FOR REFERENCE.

STOTTSBERG ENGINEERING
www.stottsbergeng.com
Project #19001

DATE:	05/28/2019
COMM No:	19-01
DRAWN BY:	GTL
CHECKED BY:	
STATE PROJECT No:	

**PLUMBING NEW WORK
PARTIAL ROOF PLAN**

MOOG, INC FACILITY AT 1213 NORTH MAIN STREET BLACKSBURG, VA 24060
MECHANICAL AND RESTROOM RENOVATIONS

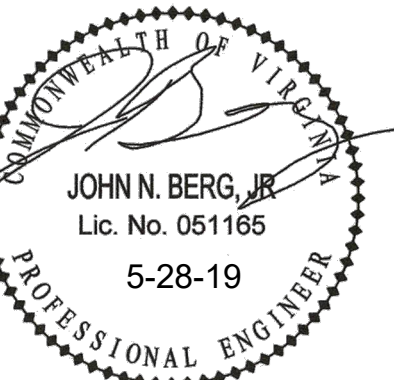

5 Design, LLC
P.O. Box 320
Riner, VA 24149
540-230-2619
www.5designarchitecture.com

REVISIONS	DESCRIPTION	DATE
No.	△	△
	△	△
	△	△
	△	△

P101

GENERAL MECHANICAL NOTES AND SPECIFICATIONS:

- ALL WORK SHALL BE IN ACCORDANCE WITH THE 2015 VIRGINIA UNIFORM STATEWIDE BUILDING CODE, ALL FEDERAL, STATE, AND CITY CODES, ORDINANCES, AND STANDARDS.
- IT IS THE INTENT OF THESE DOCUMENTS THAT THE CONTRACTOR PROVIDE ALL LABOR, MATERIAL, EQUIPMENT AND TOOLS FOR THE COMPLETE INSTALLATION OF ALL WORK SHOWN ON THE PLANS AND/OR DESCRIBED HEREIN, INCLUDING ALL DEVICES AND CONTROLS REQUIRED TO PROVIDE A COMPLETE AND FUNCTIONING SYSTEM.
- THESE DRAWINGS ARE DIAGRAMMATIC IN NATURE. NOT ALL FITTINGS, OFFSETS, VENTS, OR DRAINS ARE SHOWN. THE CONTRACTOR SHALL INCLUDE ALL OFFSETS, VENTS, AND DRAINS AS REQUIRED FOR A FULLY FUNCTIONING SYSTEM.
- IN AREAS WITH UNFINISHED CEILINGS, DUCTWORK AND PIPING SHALL BE ROUTED AS TIGHT TO THE STRUCTURE AS POSSIBLE.
- ENSURE MECHANICAL EQUIPMENT IS INSTALLED TO PROVIDE SUFFICIENT CLEARANCE FOR COIL PULL, AND MINIMUM MANUFACTURER RECOMMENDED MAINTENANCE ACCESS TO EQUIPMENT.
- ALL SUPPLY AIR DIFFUSERS, RETURN, AND EXHAUST GRILLES SHALL BE INSTALLED WITH BALANCING DAMPER LOCATED IN DUCT RUN OUT. DIFFUSERS AND GRILLES SHALL HAVE AN OPPOSED BLADE DAMPER ONLY WHEN DUCT DAMPERS ARE INACCESSIBLE.
- ALL PIPING SHALL BE LABELED FOR ITS USAGE. ALL EQUIPMENT SHALL BE PROVIDED WITH AN ENGRAVED EQUIPMENT TAG.
- ALL DUCTWORK CONSTRUCTION AND INSTALLATION SHALL COMPLY WITH THE LATEST EDITION OF THE SMACNA DUCT CONSTRUCTION HANDBOOK.
- DUCT INSULATION SHALL BE IN COMPLIANCE WITH THE 2015 IECC STANDARDS.
- FLEXIBLE DUCTS SHALL BE MECHANICALLY CORRUGATED SINGLE PLY ALUMINUM WITH CONTINUOUS WATERTIGHT LOCK SEAMS, SELF-SUPPORTING WITH 1" THICK FIBER GLASS INSULATION, MAXIMUM C FACTOR OF 0.23 BTU/HR./SQ.FT./°F AT 75°F MEAN TEMPERATURE, AND MINIMUM 4 MIL SEAMLESS VAPOR BARRIER JACKET, REINFORCED ALUMINUM FOIL, METALIZED POLYESTER LAMINATE. DUCT SHALL HAVE A WORKING PRESSURE OF NOT LESS THAN 8 INCHES W.G. AND SUITABLE FOR VELOCITIES UP TO 5000 FPM. THE ENTIRE ASSEMBLY SHALL BE RATED AND MARKED AS UL RATED.
- DUCTWORK EXPOSED TO OUTSIDE CONDITIONS SHALL BE INSULATED WITH MINIMUM 2" THICK INSULATION AND COVERED WITH MINIMUM .025 INCH THICK ALUMINUM JACKET WITH SEAMS LAPPED A MINIMUM 3", SEALED WITH SILICON CAULK. COVERS SHALL BE NEATLY FINISHED AND COMPLETELY WATERTIGHT.

BOILER SCHEDULE

MARK	WATER		CAPACITY (MBH)			AMP DRAW DATA			DIRECT VENTING		BASIS OF DESIGN	REMARKS
	DELTA T.	FUEL	INPUT	OUTPUT	AHRI EFF.	TOTAL AMPS	PUMP FLA	BLOWERS & CONTROLS	INTAKE	EXHAUST		
B-1	40	NAT. GAS	800	752	94.0	11.5	8.8	2.7	4"	6"	LOCHINVAR KBN801	

NOTES:

- BOILERS HAVE 1" GAS CONNECTION.
- SET BOILER WATER TEMPERATURE TO 135F E.W.T. AND LEAVING 175F L.W.T.
- WATER INLET AND OUTLET CONNECTIONS ARE 2".

ENERGY RECOVERY ROOFTOP UNIT SCHEDULE

TAG	WEIGHT (lbs)	QTY.	MODEL	UNIT												
				FAN CIRCUIT PER FAN			SUPPLY FAN									
				VOLTAGE	MCA (A)	MROPD (A)	TOTAL AIRFLOW (CFM)	AIRFLOW PER FAN (CFM)	ESP (inH ₂ O)	TSP (inH ₂ O)	FAN MOTOR QTY.	MOTOR HP	MOTOR BHP	MAX RPM	MOTOR TYPE	
ERU-1	7000	1	OAH021GDCC	208/60/3	36.7	40	9500	2375	2	4.43	4	3.89	2.5	3100	ECM	

RUN-AROUND ENERGY RECOVERY COIL

TOTAL CAPACITY (Btuh)	SENSIBLE CAPACITY (Btuh)	EDB(°F) / EWB(°F)	LDB(°F) / LWB(°F)	COIL APD (inH ₂ O)	EWT (°F) / LWT (°F)	GPM	PIPING RUNOUT SIZE (IN)	MAX WPD (ftH ₂ O)
58052	58052	91 / 74	85 / 72.3	0.8	80 / 90	12.1	2	4.1

CHILLED WATER COIL

EAT		LAT		TOTAL CAPACITY (Btuh)	SENSIBLE CAPACITY (Btuh)	EWT (°F)	LWT (°F)	GPM	Max WPD (ftH ₂ O)	PIPING RUNOUT SIZE (IN)
EDB (°F)	EWB (°F)	LDB (°F)	LWB (°F)							
91	74	52.4	52.2	667030	372429	44	54	135	17.3	2.5

HOT WATER COIL

TOTAL HEATING (Btuh)	EDB (°F) / LDB (°F)	GPM	MAX WPD (ftH ₂ O)	PIPING RUNOUT SIZE (IN)	EWT (°F) / LWT (°F)
1036796	-10 / 97.5	51.1	9.2	2.5	175 / 135

NOTES:

- BASIS OF DESIGN IS DAIKIN VISION AIR HANDLING UNIT.
- PROVIDE SINGLE POINT POWER CONNECTION WITH FACTORY MOUNTED NON-FUSED DISCONNECT.
- FILTERS ARE A COMBINATION OF 2" MERV8 AND 4" MERV13 FILTERS.
- PROVIDE WITH FACTORY CUSTOM 16" ROOF CURB.
- WATER SHALL BE 30% PROPYLENE GLYCOL.

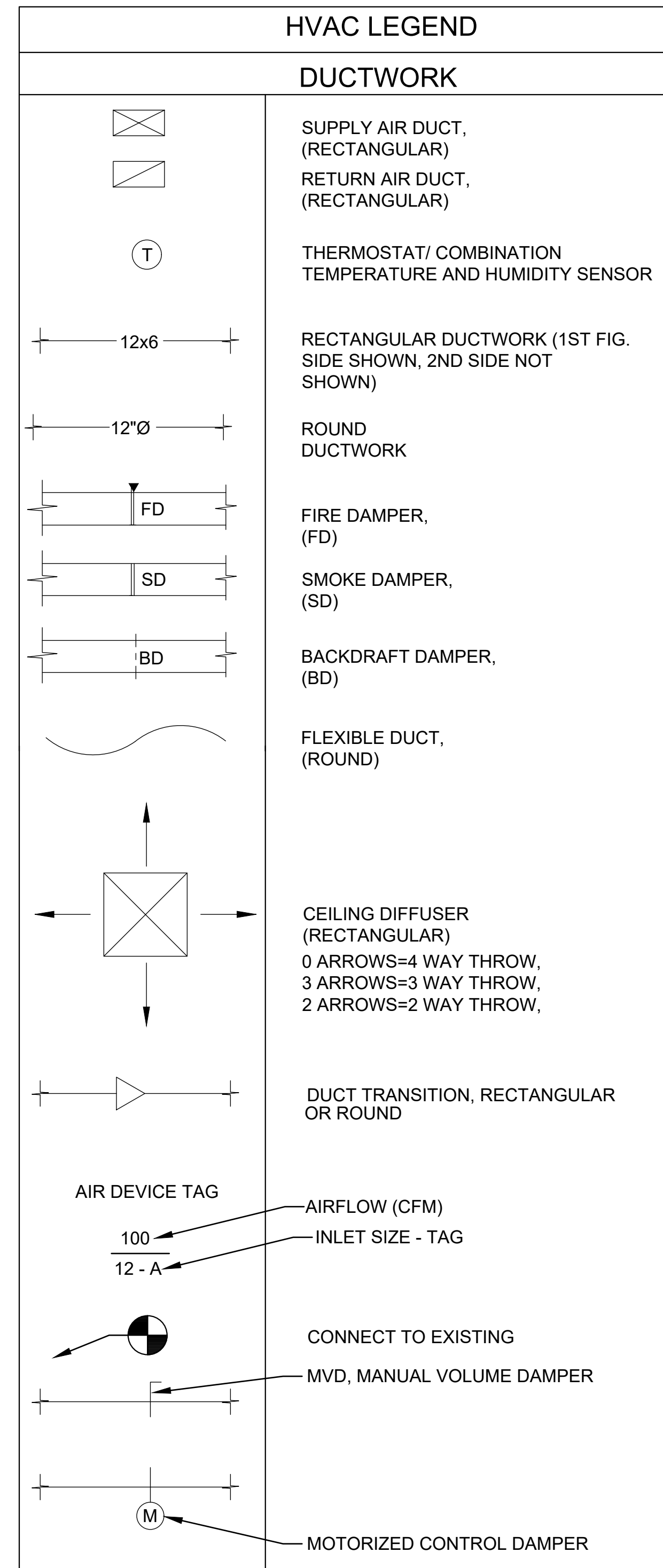

DATE: 05/28/2019
 COMM No: 19-01
 DRAWN BY: GTL
 CHECKED BY: JNB
 STATE PROJECT No: _____

MECHANICAL GENERAL NOTES, LEGEND, & SCHEDULES

MOOG, INC FACILITY AT 1213 NORTH MAIN STREET BLACKSBURG, VA 24080
 MECHANICAL AND RESTROOM RENOVATIONS

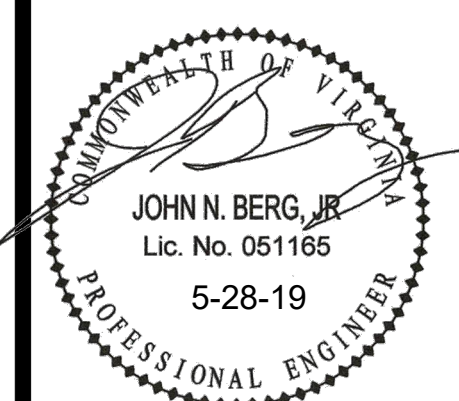

5 Design, LLC
 P.O. Box 320
 Riner, VA 24149
 540-230-2619
 www.5designarchitecture.com

REVISIONS	DATE	DESCRIPTION
No. 1	5-29-19	OWNER REVIEW

M001

www.stottsbergeng.com
 Project #19001

15 of 23

AIR DEVICE SCHEDULE					
MARK	SERVICE	MOUNTING	FINISH	BASIS OF DESIGN	NOTES
A	SUPPLY	LAY-IN	WHITE	PRICE, AMD - LOUVERED FACE DIRECTIONAL DIFFUSER	-
B	RETURN	LAY-IN	WHITE	PRICE, 80 - EGG CRATE GRILLE	-
C	EXHAUST	SURFACE / LAY-IN	WHITE	PRICE, RCG	1
D	SUPPLY	DUCT	ALUM. POWDER COAT	PRICE, HCD1, HIGH CAPACITY DRUM LOUVER	-

NOTES:
 1. PROVIDE WITH OPPOSED BLADE DAMPER IF MANUAL VOLUME DAMPER IS NOT PROVIDED FOR BALANCING AT TAKEOFF.

EXHAUST FAN SCHEDULE								
MARK	QUANTITY	AIR FLOW (CFM)	ESP	BRAKE HP	NOM HP	DRIVE TYPE	V/FREQ./PH	BASIS OF DESIGN
F-1	1	850	0.30"	0.07	1/4	DIRECT	115/60/1	GREENHECK, G-123-VG

NOTES:
 1. INTERLOCK WITH RTU-1
 2. PROVIDE ALL FANS WITH GRAVITY BACKDRAFT DAMPER EITHER IN CURB OR AT FAN DISCHARGE.
 3. ROOF MOUNTED FANS SHALL BE PROVIDED WITH 12" ROOF CURB.

ENERGY RECOVERY COIL SCHEDULE										
MARK	COIL DESCRIPTION (QUANTITY)	FLUID FLOW (GPM)	EAT °F (DB/WB)	LAT °F (DB/WB)	AIRFLOW (CFM)	TOTAL CAPACITY (Btuh)	SENSIBLE CAPACITY (Btuh)	APD (inH2O)	WPD (ftH2O)	EWTL/LWT (°F)
EXH-1	5W11305A 24x24 (1)	9.27	70.0/58.4	55.0/54.5	2675	45.0	43.3	0.62	17.45	44 / 54
EXH-2	5W11205A 12x12 (1)	1.62	70.0/58.4	55.0/54.5	468	7.8	7.5	0.33	4.98	44 / 54
EXH-3	5W10805C 15x15 (1)	1.62	70.0/58.4	55.0/54.5	468	7.9	7.6	0.15	1.53	44 / 54
EXH-4	5W11204A 12x12 (1)	1.96	70.0/58.4	55.0/54.5	564	9.4	9.0	0.47	6.89	44 / 54
EXH-5	5W11204A 12x12 (1)	0.93	70.0/58.4	55.0/54.5	267	4.4	4.3	0.11	1.55	44 / 54

PUMP SCHEDULE									
MARK	QUANTITY	FLUID FLOW (GPM)	FLUID	PUMP HEAD FT.	NOM HP	RPM	TYPE	V/FREQ./PH	BASIS OF DESIGN
P-1	1	106.8	HOT WATER	85.0	5.0	1750	BASE MOUNTED	208/60/3	BELL & GOSSETT 1531
P-2	1	15.4	30% PROPYLENE GLYCOL	32.0	1.0	1750	INLINE	208-230/60/3	BELL & GOSSETT PD38T
P-3	2	51.0	HOT WATER	29.0	1.0	1750	INLINE	208-230/60/3	BELL & GOSSETT PD 38T
BP-1	2	70.0	HOT WATER	20.0	1.0	1750	INLINE	208-230/60/3	BELL & GOSSETT PD38T

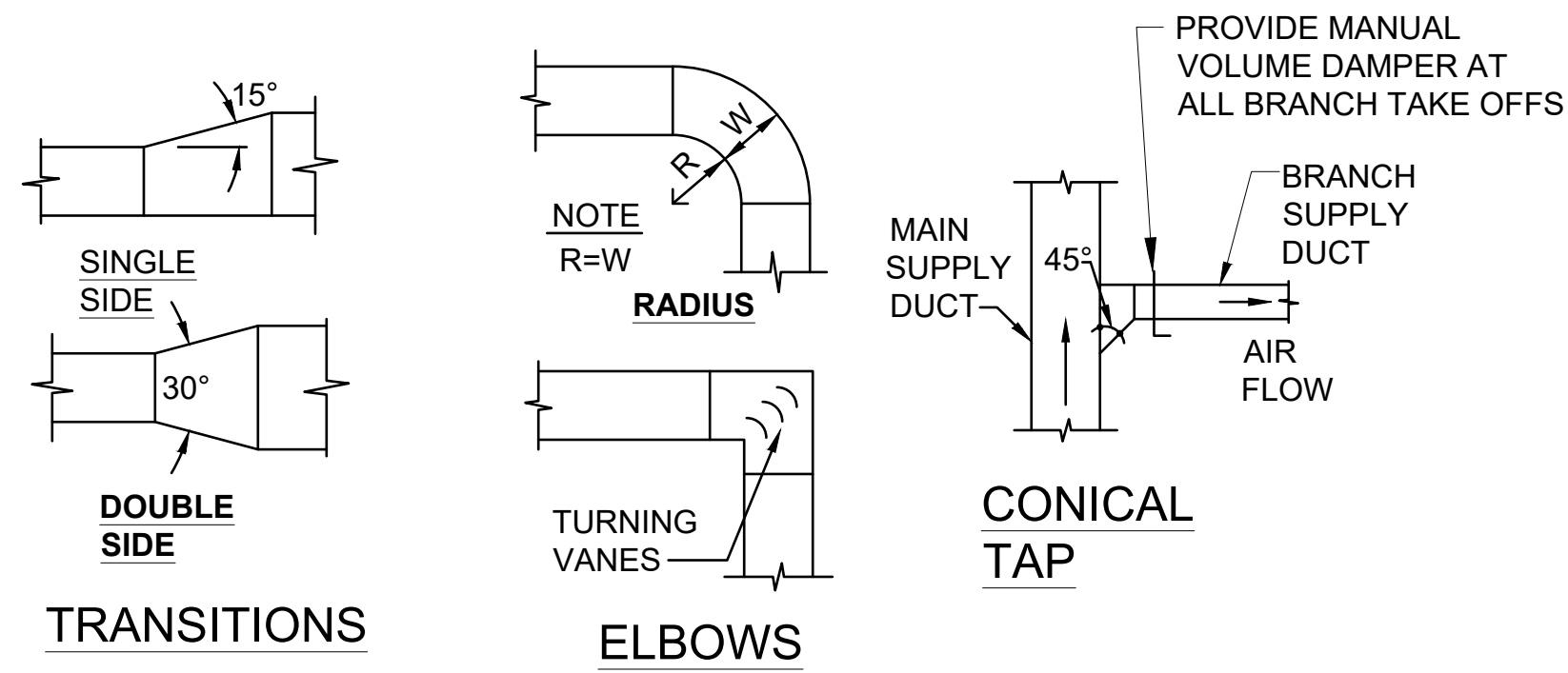

1 M002 DUCTWORK DETAILS SCALE = N/A

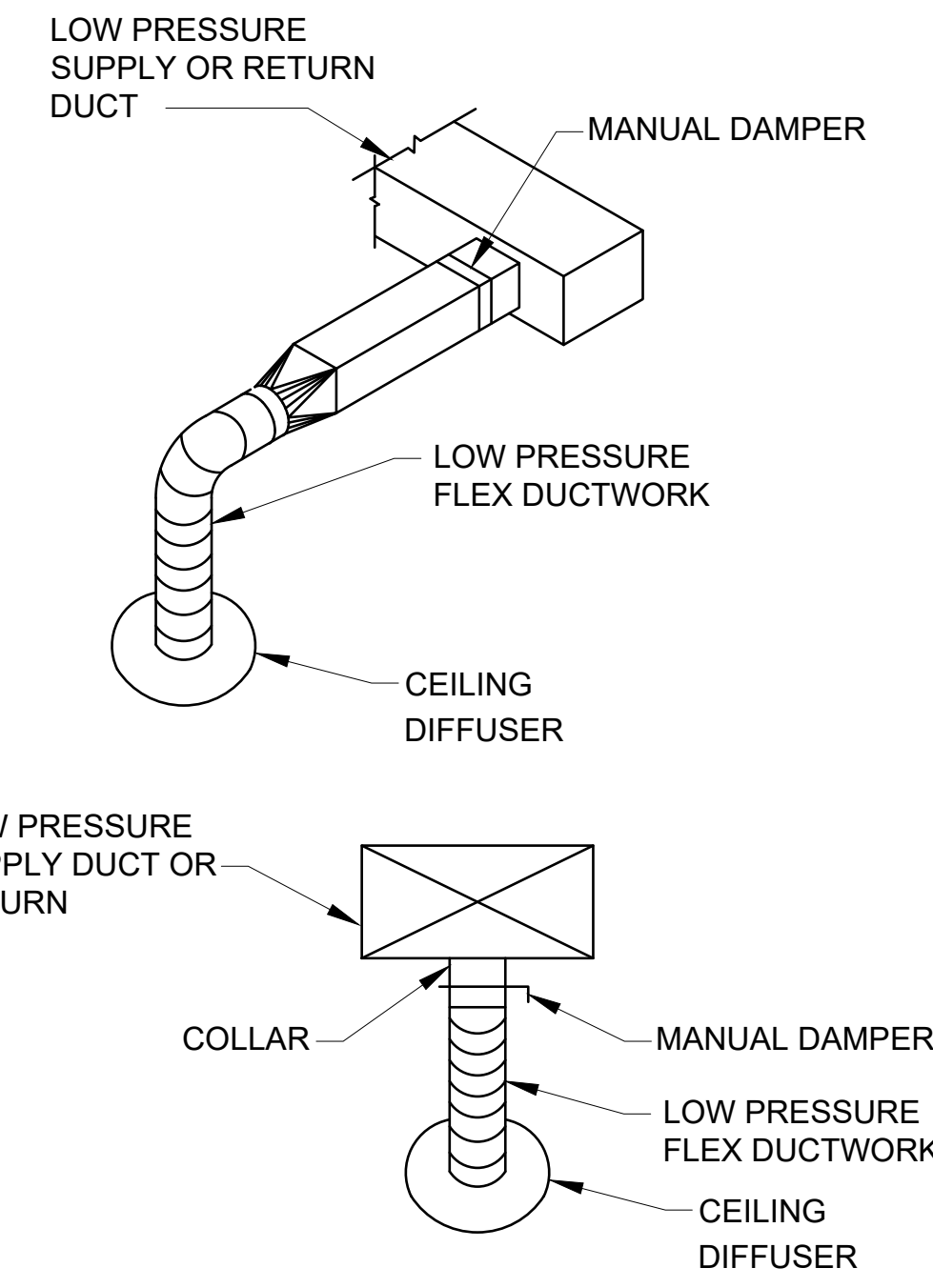

2 M002 FLEX DUCT TO DIFFUSER DETAIL SCALE = N/A

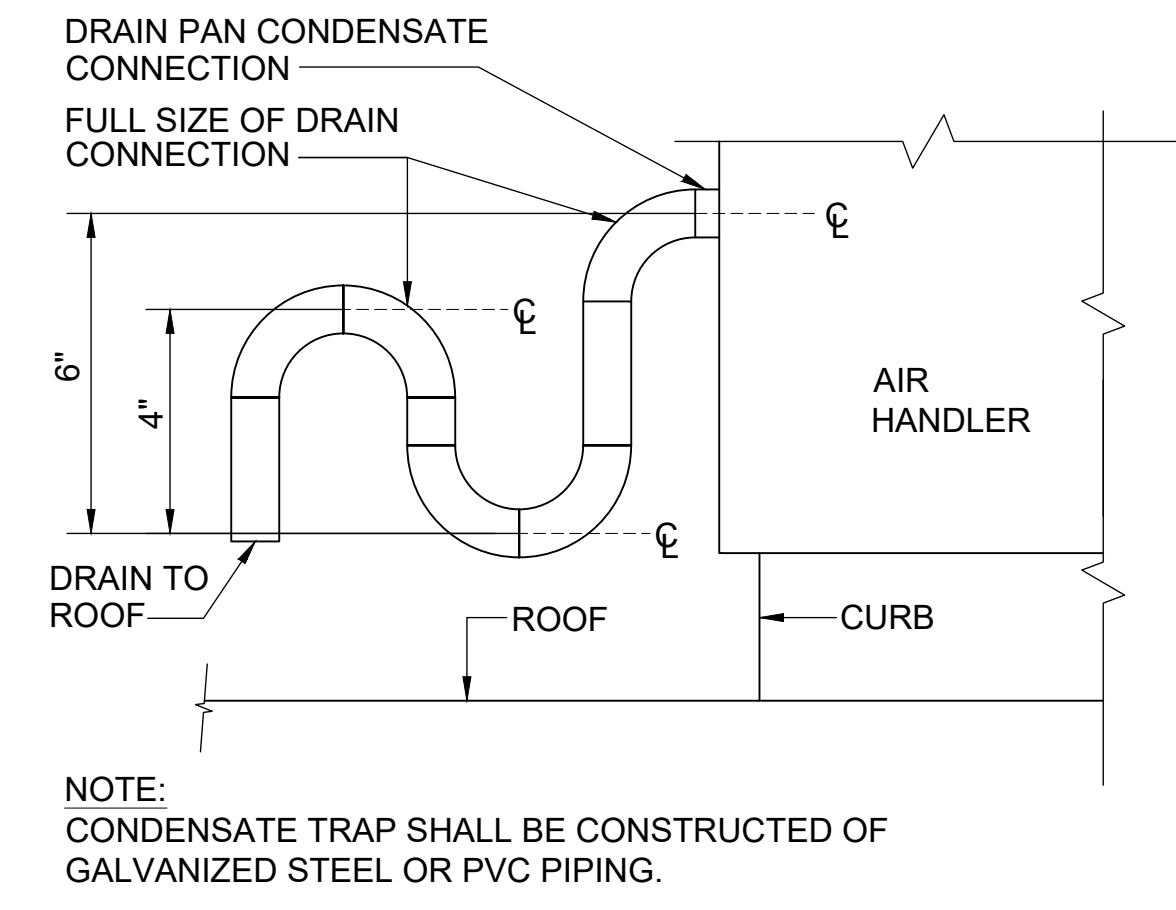

3 M002 CONDENSATE DRAIN DETAIL SCALE = N/A

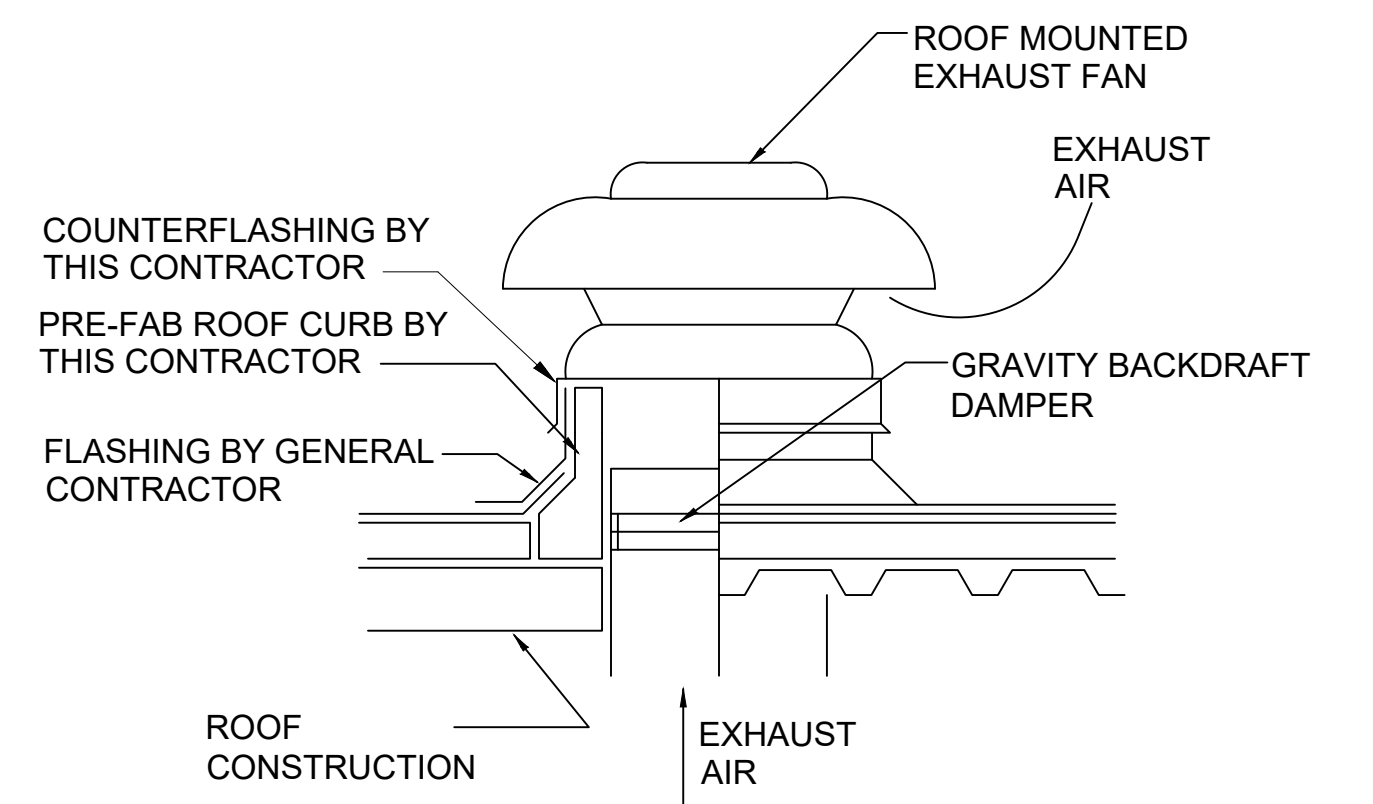

4 M002 EXHAUST FAN (ROOF DOWN BLAST) SCALE = N/A

DATE: 05/28/2019
 COMM No: 19-01
 DRAWN BY: GTL
 CHECKED BY: JNB
 STATE PROJECT No: MOOG, INC FACILITY AT 1213 NORTH MAIN STREET BLACKSBURG, VA 24060
 MECHANICAL AND RESTROOM RENOVATIONS

MECHANICAL DETAILS & SCHEDULES



5 Design, LLC
 P.O. Box 320
 Riner, VA 24149
 540-230-2619
 www.5designarchitecture.com

REVISIONS	DATE	DESCRIPTION
No. 1	▲	▲
No. 2	▲	▲
No. 3	▲	▲
No. 4	▲	▲

M002

16 of 23

STOTTSBERG ENGINEERING
 www.stottsbergeng.com
 Project #19001

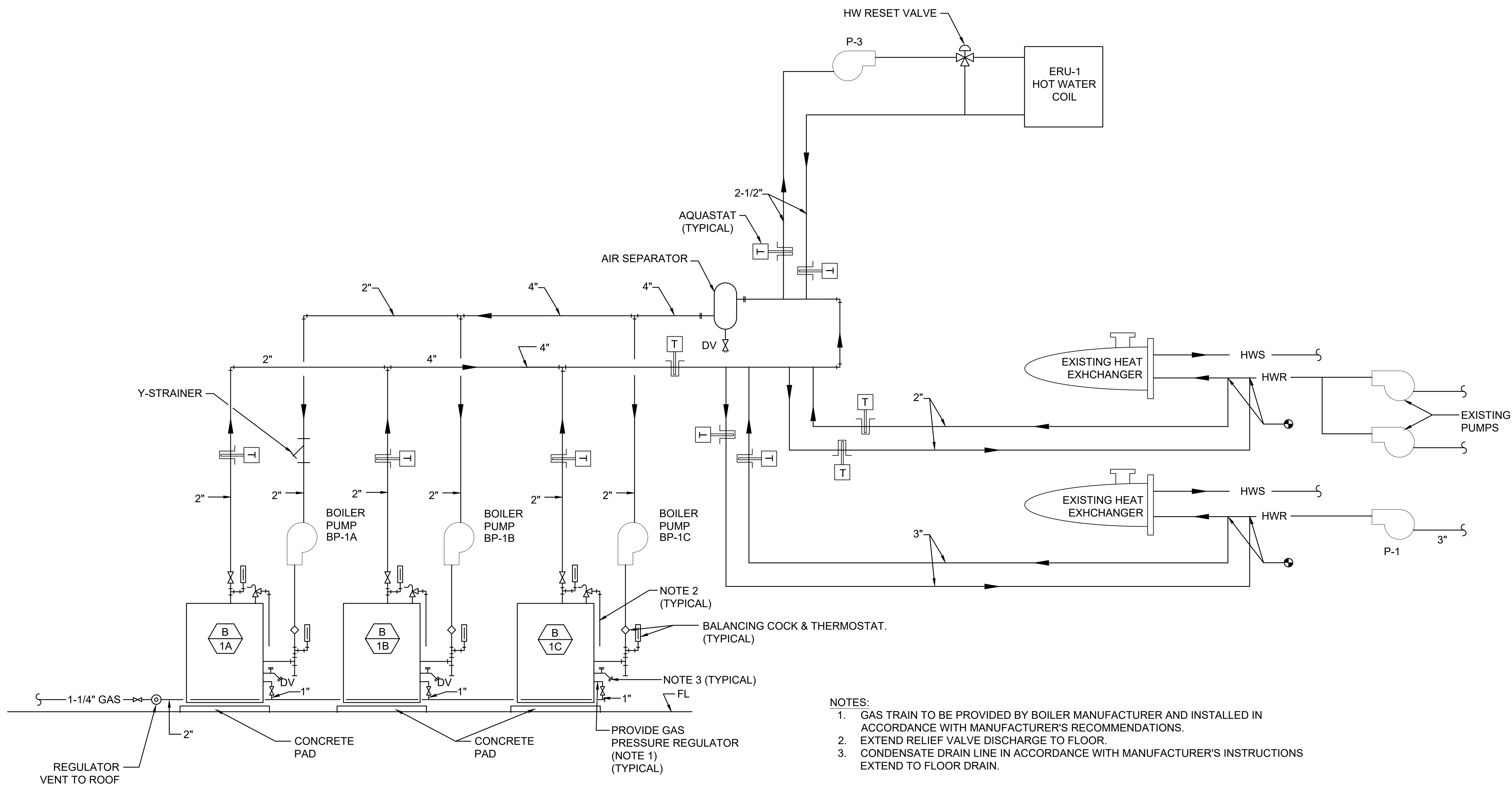

1 HEATING WATER SYSTEM
SCALE = N/A

- NOTES:
1. GAS TRAIN TO BE PROVIDED BY BOILER MANUFACTURER AND INSTALLED IN ACCORDANCE WITH MANUFACTURER'S RECOMMENDATIONS.
 2. EXTEND RELIEF VALVE DISCHARGE TO FLOOR.
 3. CONDENSATE DRAIN LINE IN ACCORDANCE WITH MANUFACTURER'S INSTRUCTIONS EXTEND TO FLOOR DRAIN.

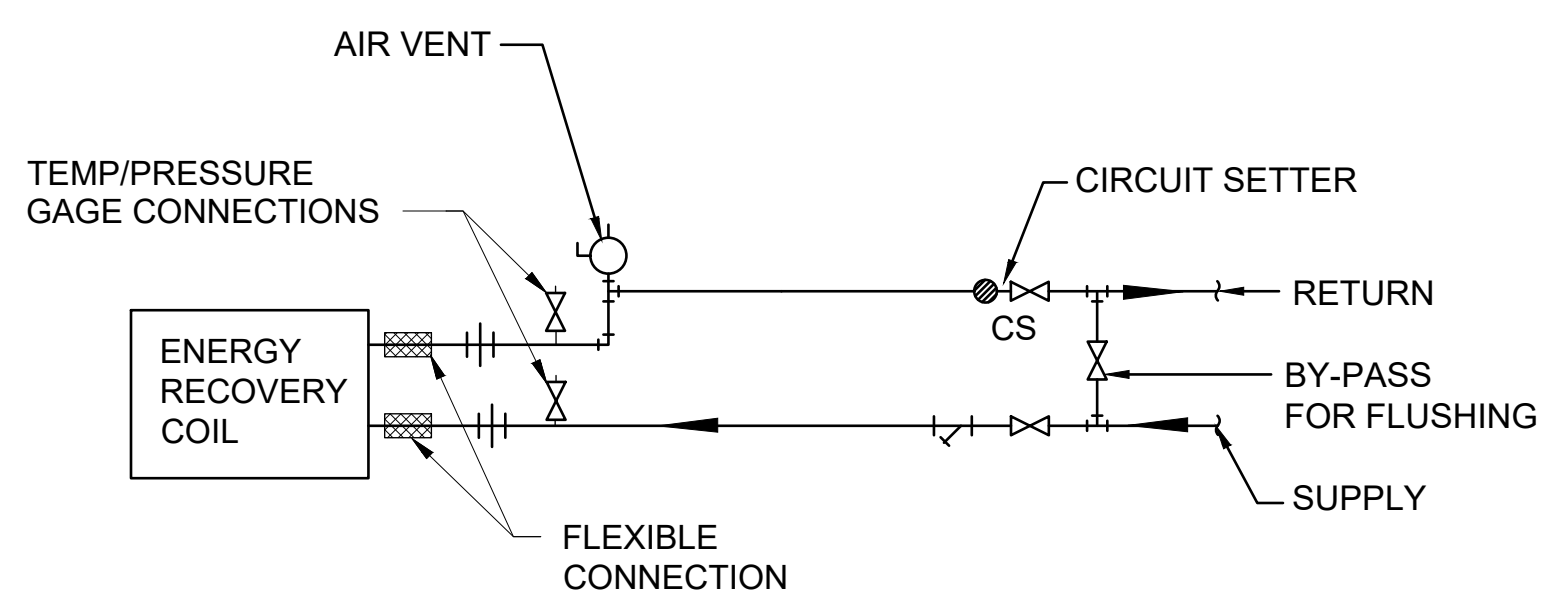

2 ENERGY RECOVERY COIL SCHEMATIC
SCALE = N/A

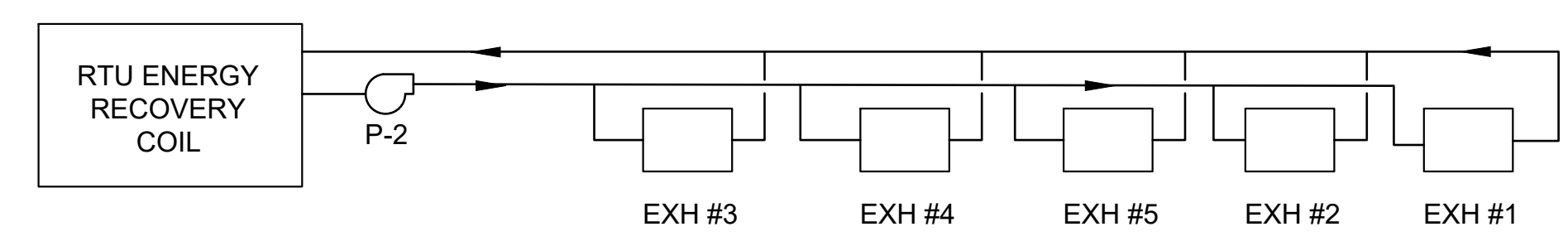

3 ENERGY RECOVERY COIL SCHEMATIC
SCALE = N/A

STOTTSBERG ENGINEERING
www.stottsbergeng.com
Project #19001

DATE:	05/28/2019
COMM No:	19-01
DRAWN BY:	GTL
CHECKED BY:	JNB
STATE PROJECT No:	

MECHANICAL DETAILS

MOOG, INC FACILITY AT 1213 NORTH MAIN STREET BLACKSBURG, VA 24060
MECHANICAL AND RESTROOM RENOVATIONS

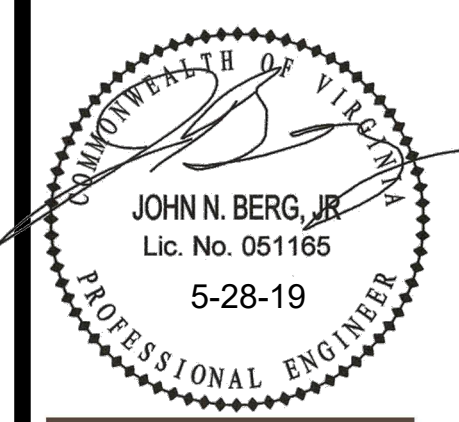

5 Design, LLC
P.O. Box 320
Riner, VA 24149
540-230-2619
www.5designarchitecture.com

REVISIONS	DATE	DESCRIPTION
No.	<	<

M003

GENERAL SPECIFICATIONS

1. SCOPE:
 PROVIDE ALL MATERIALS, LABOR, TOOLS AND INCIDENTALS NECESSARY TO INSTALL AND MAKE READY FOR OWNER'S USE COMPLETE SYSTEMS OF HEATING, VENTILATION, AIR CONDITIONING (HVAC), PLUMBING, FOR THE PROPOSED WORK AND BUILDING RENOVATIONS AS SHOWN ON THE DRAWINGS AND CALLED FOR IN THESE SPECIFICATIONS.
 VISIT THE SITE TO OBTAIN DIMENSIONS, EXISTING LAYOUTS AND LOCATIONS AND EXISTING CONSTRUCTION DETAILS NOT SHOWN ON THESE DRAWINGS.
 THE CONTRACTOR IS RESPONSIBLE FOR THE COORDINATION WITH OTHER DIVISIONS OF WORK FOR THE FULL EXTENT OF THE SCOPE. IT IS THE CONTRACTOR'S RESPONSIBILITY TO FIELD VERIFY ALL ASPECTS, COMPONENTS, SYSTEMS, ETC. AND ACCOMMODATE THE PERFORMANCE INTENT OF THE CONSTRUCTION DOCUMENTS THROUGHOUT THE PROJECT SCOPE.

2. BIDDERS RESPONSIBILITY:
 EXAMINE THE DRAWINGS AND SPECIFICATIONS AND VISIT THE WORK SITE. BECOME FAMILIAR WITH THE CHARACTER OF THE WORK, THE COORDINATION WITH OTHER TRADES REQUIRED, AND ANY OTHER CONDITIONS THAT AFFECT THE COMPLETION OF THIS WORK. GENERAL CONTRACTOR SHALL BE REQUIRED TO COORDINATE WORK WITH TENANT FINISH CONTRACTOR IN A SIDE BY SIDE SCENARIO.

3. PERMITS, CODES AND LAWS:
 APPLY FOR ALL PERMITS AND PAY ALL FEES.
 ALL WORK SHALL BE IN ACCORDANCE WITH LATEST EDITIONS OF THE FOLLOWING RULES AND REGULATIONS, HEREIN REFERRED TO AS "CODES":
 THE LATEST OR ADOPTED EDITION OF THE APPLICABLE LOCAL, STATE, AND FEDERAL BUILDING, MECHANICAL, SANITATION, PLUMBING, ETC. CODES.
 UNDERWRITER'S LABORATORIES, INC. (U.L) NATIONAL FIRE PROTECTION ASSOCIATION (N.F.P.A.) OCCUPATIONAL SAFETY AND HEALTH ADMINISTRATION (O.S.H.A)
 WHERE ANY OF THESE CODES ARE AT VARIANCE WITH THE DRAWINGS AND SPECIFICATIONS, THEIR REQUIREMENTS SHALL TAKE PRECEDENCE, UNLESS THE DRAWINGS AND SPECIFICATIONS REQUIREMENTS EXCEED THESE CODES. INCLUDE ANY COST NECESSARY TO MEET THESE CODES IN THE BID PRICE.

4. MECHANICAL PLANS:
 THE MECHANICAL PLANS ARE DIAGRAMMATIC AND BASED ON ONE MANUFACTURER'S EQUIPMENT.
 THEY ARE NOT INTENDED TO SHOW EVERY ITEM IN ITS EXACT LOCATION, THE EXACT DIMENSIONS, OR ALL THE DETAILS OF THE EQUIPMENT. VERIFY THE ACTUAL DIMENSIONS OF THE EQUIPMENT PROPOSED TO BE USED.
 INSTALLATION SHALL BE WITHIN THE LIMITATIONS IMPOSED BY THE ARCHITECTURAL, STRUCTURAL, HVAC, ELECTRICAL, AND PLUMBING REQUIREMENTS WITH ADEQUATE SPACE FOR MAINTENANCE.

5. QUESTIONS AND CLARIFICATIONS OF BID DOCUMENTS:
 BIDDERS SHALL NOT RELY ON ANY ORAL CLARIFICATION OF THE DRAWINGS OR SPECIFICATIONS. ANY QUESTIONS OR CLARIFICATIONS SHALL BE REFERRED IN WRITING TO THE ARCHITECT.

6. GUARANTEES:
 ALL EQUIPMENT, MATERIALS, AND WORKMANSHIP SHALL BE GUARANTEED IN WRITING FOR A PERIOD OF ONE YEAR FROM THE DATE OF FINAL ACCEPTANCE. WARRANTIES SHALL BE IN WRITING AND SHALL INCLUDE FACTORY WARRANTIES FOR EACH PIECE OF EQUIPMENT. PROVIDE A CERTIFICATE FOR EACH PIECE OF EQUIPMENT. CLEARLY INDICATE ON EACH WARRANTY CERTIFICATE THE MODEL NO., SERIAL NO., LOCATION, AND OWNER'S NAME.

7. COMPLETE SYSTEM:
 ALL PRODUCTS, MATERIALS AND ACCESSORIES SHALL BE FURNISHED AND INSTALLED AS REQUIRED FOR A COMPLETE SYSTEM READY FOR OWNER'S BENEFICIAL USE.

8. WORKMANSHIP:
 ALL WORK SHALL BE PERFORMED BY COMPETENT MECHANICS USING PROPER TOOLS AND EQUIPMENT TO PRODUCE FIRST QUALITY WORK. ALL WORK SHALL BE NEATLY INSTALLED, ACCESSIBLE FOR MAINTENANCE, AND COMPLETE WITH ALL ACCESSORIES REQUIRED.

9. ACCESSIBILITY:
 INSTALL ALL EQUIPMENT AND THEIR APPURTENANCES SUCH AS, BUT NOT LIMITED TO, VALVES, COILS, DRAIN PANS, DRAINS, DAMPERS, CONTROLS, MOTORS, CONTROLLERS, ETC., SO THAT THEY CAN BE SERVICED, RESET, REPLACED OR RECALIBRATED, ETC. INSTALL ALL NECESSARY ACCESS PANELS AND BUILDING ACCESS DOORS, AS BELOW, WHERE REQUIRED TO ACCOMPLISH THIS. IF ANY EQUIPMENT OR COMPONENTS DO NOT FIT WHERE INTENDED, THE CONTRACTOR SHALL NOTIFY THE ARCHITECT IN WRITING, REQUESTING FURTHER GUIDANCE.
 PROVIDE BUILDING ACCESS DOORS FOR ALL MECHANICAL EQUIPMENT REQUIRING SERVICE, INCLUDING BUT NOT LIMITED TO, AHU'S, FANS, DAMPERS, DUCT ACCESS PANELS, CONTROLS, PIPING, VALVES, REGULATORS, TRAPS, ETC., INSTALLED ABOVE HARD CEILINGS, BEHIND WALLS, AND BELOW FLOORS, FOR INSTALLATION BY OTHER DIVISIONS OF THE WORK. BUILDING ACCESS DOORS ARE NOT REQUIRED WHERE THE MECHANICAL EQUIPMENT IS INSTALLED ABOVE LAY-IN AND ACCESSIBLE SPLINE CEILINGS. OTHER TYPES OF SPLINE CEILINGS REQUIRE BUILDING ACCESS DOORS.
 SIZE THE BUILDING ACCESS DOORS FOR THE USE INTENDED, BUT NOT LESS THAN 12 INCHES BY 12 INCHES. WHERE HUMAN ACCESS IS REQUIRED, PROVIDE 24 INCHES BY 24 INCHES, OR LARGER. WHERE BUILDING ACCESS DOORS CANNOT BE INSTALLED FOR STRUCTURAL OR ARCHITECTURAL REASONS, NOTIFY THE ARCHITECT.
 PRIME COAT BUILDING ACCESS DOORS IN PAINTED AREAS WITH FINISH PAINTING AS SPECIFIED IN OTHER DIVISIONS.
 IN WET AREAS, TOILET ROOMS, OR AREAS WITH CERAMIC TILE FLOORS OR WALLS, PROVIDE STAINLESS STEEL BUILDING ACCESS DOORS.
 PROVIDE BUILDING ACCESS DOORS WITH A CONCEALED KEY OPERATED LOCK AND CONCEALED HINGES. ALL LOCKS SHALL BE KEYED ALIKE.
 PROVIDE BUILDING ACCESS DOORS AS SPECIFIED IN OTHER DIVISIONS OF THE WORK OR PROVIDE MILCOR DOORS, OR EQUIVALENT, SUITABLE FOR THE INSTALLATION INTENDED. PROVIDE FIRE RATED DOORS FOR ALL FIRE RATED WALLS, PARTITIONS, AND CEILINGS.

10. WORK BY OTHER TRADES:
 FURNISH ALL SLEEVE FRAMES, BUILDING ACCESS DOORS, PREFABRICATED EQUIPMENT CURBS, ROOF CURBS, ETC. FOR INSTALLATION BY OTHER TRADES.
 INSTALL ALL MOTORS AND FURNISH THE STARTING EQUIPMENT AND DISCONNECTS TO THE DIVISION 26000 SUBCONTRACTOR FOR INSTALLATION. CONTROL WIRING, INCLUDING SWITCHES, THERMOSTATS, INTERLOCKS, ETC. SHALL BE FURNISHED BY DIVISION 23000. ENSURE THAT THE ELECTRICAL EQUIPMENT MOUNTED NEAR THE MECHANICAL EQUIPMENT DOES NOT BLOCK ACCESS TO SERVICE AREAS OF THE MECHANICAL EQUIPMENT. DO NOT ALLOW ANY EQUIPMENT TO BE INSTALLED ON THE HVAC EQUIPMENT ENCLOSURES.

11. FIRE STOPPING:
 ALL PENETRATIONS OF FLOORS AND OTHER FIRE-RATED ASSEMBLIES SHALL BE FIRE AND SMOKE-STOPPED IN STRICT ACCORDANCE WITH THE APPLICABLE CODES.

12. FOUNDATIONS AND SPECIAL SUPPORTS:

FURNISH AND INSTALL ALL SPECIAL FOUNDATIONS AND SUPPORTS REQUIRED FOR EQUIPMENT INSTALLED UNDER THIS SECTION, UNLESS THEY ARE A PART OF THE BUILDING STRUCTURE AND ARE SHOWN IN OTHER SECTIONS.

13. CLEANING AND PAINTING:
 THOROUGHLY CLEAN ALL EQUIPMENT AND REMOVE ALL TRASH, CARTONS, ETC. MAKE ANY NECESSARY CORRECTIONS OR REPAIR/REPLACE ANY DAMAGED MATERIALS OR EQUIPMENT. LEAVE THE ENTIRE SYSTEM IN A THOROUGHLY CLEAN AND ORDERLY MANNER.
 ANY FINISHED SURFACES THAT HAVE BEEN SCRATCHED OR DISCOLORED SHALL BE TOUCHED-UP OR REPAINTED BREAK TO BREAK WITH PAINT TO MATCH THE ORIGINAL COLOR. TOUCH UP PAINTED SURFACES OR REPAINT THE ENTIRE PAINTED SURFACE IF TOUCH UP IS UNACCEPTABLE. SEE ARCHITECTURAL PAINTING SPECIFICATIONS.
 ALL METAL ITEMS SUBJECT TO RUSTING, INSIDE OR EXPOSED TO WEATHER SHALL BE GIVEN ONE COAT OF PROPER TYPE RUST PREVENTATIVE PRIMER AS SOON AS INSTALLED. APPLY TWO FINISH COATS WITH COLOR TO BE SELECTED BY THE ARCHITECT.
 FOR ALL INTERIOR OR EXTERIOR STRUCTURAL GALVANIZED STEEL, COLD GALVANIZE ALL EXPOSED METAL CUT ENDS, HOLES, WELDS, SCRATCHES, ETC., OR HOT DIP GALVANIZE THE ENTIRE STRUCTURE OR FRAME AFTER FABRICATION AND MOUNTING HOLES ARE CUT.
 UPON COMPLETION OF THE INSTALLATION, BUT NOT BEFORE, AND BEFORE ACCEPTANCE, THOROUGHLY CLEAN ALL EXPOSED EQUIPMENT, PIPING, DUCTWORK, INSULATION JACKETS, ETC., REMOVING ALL STICKERS, LABELS, MARKING, WRITING, FABRICATION MARKINGS, IDENTIFICATION, ADHESIVE, SEALER, GLUE, RUST, CORROSION, ETC., FROM THEIR EXTERIOR SURFACES.
 THE CLEANLINESS AND PAINTING ACCEPTABILITY IS AT THE SOLE DISCRETION OF THE ARCHITECT AND MAY REQUIRE ADDITIONAL CLEANING AND COATS OF PAINT BEFORE ANY SURFACE IS ACCEPTED.

14. SUBMITTAL AND SHOP DRAWINGS:
 SUBMIT MANUFACTURER'S CERTIFIED DATA RELATIVE TO ALL EQUIPMENT, PIPING, CONTROLS, ETC. REQUIRED FOR THE INSTALLATION OF THE HVAC, PLUMBING AND FIRE PROTECTION SYSTEMS. SUBMIT FOR REVIEW ALL NECESSARY ENGINEERING, PRODUCT AND INSTALLATION DATA, SHOP DRAWINGS, SAMPLES ETC. FOR ALL EQUIPMENT, MATERIAL, AND SYSTEMS TO ASCERTAIN COMPLIANCE WITH THE TECHNICAL REQUIREMENTS OF THE CONTRACT DOCUMENTS. SUBMIT SIX (6) COPIES OF ALL NECESSARY DATA, CUTS, MANUFACTURER'S SELECTIONS, CATALOGS, BULLETINS, INSTALLATION INSTRUCTIONS, DRAWINGS, DIAGRAMS, CURVES, ETC. CLEARLY INDICATE ON THE SUBMITTED DATA, THE MANUFACTURER'S NAME, PRODUCT NUMBER(S), OPTIONS, EQUIPMENT CAPACITY, DIMENSIONAL DATA, WEIGHTS, AND OTHER APPLICABLE TECHNICAL DATA FOR THE PROJECT.
 TRADE NAMES, MANUFACTURERS, AND CATALOGUE NUMBERS ARE MENTIONED HEREIN AND ON THE DRAWINGS SOLELY IN ORDER TO ESTABLISH A STANDARD FOR THE TYPE, GENERAL DESIGN, AND QUALITY OF PRODUCT REQUIRED. OTHER PRODUCTS SIMILAR IN DESIGN OF EQUIVALENT QUALITY CAPABLE OF FITTING WITHIN THE SPACES ALLOCATED AND COMPLYING WITH THE DRAWINGS AND SPECIFICATIONS WILL BE CONSIDERED AFTER THE CONTRACT IS LET UNLESS "PRIOR APPROVAL" REQUIREMENTS ARE SET FORTH IN THESE DOCUMENTS.
 WHERE TWO OR MORE MANUFACTURERS OR MATERIALS ARE NAMED, THE CONTRACTOR MAY SUBMIT ANY OF THOSE NAMES, PROVIDED THEY CONFORM TO THE SPECIFICATIONS AND DESIGN INTENT. CONTRACTOR SHALL INCLUDE WITH THE SUBMITTAL A LIST OF ALL COMPARATIVE FEATURES INDICATING COMPLIANCE WITH THE SPECIFICATIONS.
 THE ARCHITECT AND/OR ENGINEER MAY REQUIRE THE SUBMISSION OF SAMPLES, PARTICULARLY WHEREVER EQUIPMENT OR APPLIANCES ARE VISIBLE IN FINISHED AREAS, SUCH AS CEILINGS, INTERIOR AND EXTERIOR WALLS. THE CONTRACTOR AND SUPPLIER SHALL ARRANGE FOR DEMONSTRATIONS OF THE INSTALLATION OF ANY OF THESE PRODUCTS AND THEIR ABILITY TO PERFORM AS SPECIFIED, IF REQUIRED.
 REVIEW OF SUBMITTALS AND SHOP DRAWINGS DOES NOT RELIEVE THE CONTRACTOR OF THE RESPONSIBILITY FOR FITTING THE EQUIPMENT IN THE SPACE ALLOTTED WITH SPACE FOR ALL CONNECTIONS AND SERVICING AND FOR THE COORDINATION OF THE WORK WITH WORK OF OTHER TRADES.

THE CONTRACTOR SHALL REVIEW ALL SUBMITTALS AND SHOP DRAWINGS AND INDICATE BY STAMP OR LETTER THAT HE HAS REVIEWED THEM, BEFORE FORWARDING THEM TO THE ARCHITECT AND/OR ENGINEER. SUBMITTALS AND DRAWINGS WILL BE RETURNED AFTER REVIEW INDICATING WHETHER EXCEPTIONS ARE TAKEN, THE SUBMITTAL RETURNED WITH CORRECTIONS, OR IS COMPLETELY REJECTED. RESUBMISSION OF REVISED SUBMITTALS AND SHOP DRAWINGS, IF REQUIRED, SHALL BE DONE BEFORE INSTALLATION AND CONSTRUCTION IS BEGUN.
 CORRECTIONS OR COMMENTS MADE ON THE SUBMITTALS AND DRAWINGS DURING THIS REVIEW DOES NOT RELIEVE THE CONTRACTOR FROM COMPLIANCE WITH THE REQUIREMENTS OF THE CONTRACT DOCUMENTS. THIS REVIEW IS FOR GENERAL CONFORMANCE WITH THE DESIGN CONCEPT OF THE PROJECT AND GENERAL COMPLIANCE WITH THE INFORMATION GIVEN IN THE CONTRACT DOCUMENTS. THE CONTRACTOR IS RESPONSIBLE FOR CONFIRMING AND CORRELATING ALL QUANTITIES AND DIMENSIONS, FABRICATION PROCESSES, TECHNIQUES OF CONSTRUCTION, COORDINATING THE WORK WITH THAT OF ALL OTHER TRADES, AND PERFORMING WORK IN A SAFE AND SATISFACTORY MANNER. REVIEW OF THE SUBMITTALS SHALL NOT PERMIT ANY DEVIATION FROM PLANS AND SPECIFICATIONS.
 SUBMITTALS FOR A SPECIFIC CLASS OF PRODUCTS, SYSTEMS, INSTALLATION PROCEDURES, SHOP DRAWINGS, ETC. WILL BE REVIEWED BY THE ENGINEER ONE TIME AND ITS RESUBMITTAL ONE TIME, IF NECESSARY, AS ABOVE, AT NO COST TO THE CONTRACTOR. THE CONTRACTOR WILL BEAR THE FULL COST FOR ALL SUBSEQUENT RESUBMITTAL REVIEWS AT THE ENGINEER'S STANDARD HOURLY RATES. PAYMENT WILL BE REQUIRED AT COMPLETION OF RESPECTIVE REVIEW.
 REQUIRED SHOP DRAWINGS:
 SUBMIT THE FOLLOWING SHOP DRAWINGS BEFORE ANY MECHANICAL DUCTWORK, PIPING, EQUIPMENT, ETC. IS FABRICATED AND INSTALLED. SUBMIT THESE SHOP DRAWINGS IN 1/4 INCH PER FOOT MINIMUM SCALE WITH NECESSARY PLANS, ELEVATIONS, SECTIONS, DETAILS, AND ISOMETRICS. SUBMIT SIX (6) PAPER COPIES AND ONE (1) CD-ROM WITH ALL THESE DRAWINGS IN AUTOCAD DRAWING DWG FILES, LATEST AUTOCAD FORMAT.
 SOON AFTER AWARD OF THE CONTRACT, DETERMINE WHERE THERE MAY BE INSTALLATION, SPACE CONCERNS, AND/OR WHERE OTHER CONFLICTS MAY OCCUR. SUBMIT COORDINATION DRAWINGS, RELATING TO THESE CONFLICTS WITH THE MECHANICAL EQUIPMENT, DUCT, PIPING, ELECTRICAL, STRUCTURAL AND ARCHITECTURAL SYSTEMS ETC., SHOWING CLEARANCES AND RELATIONSHIP TO STRUCTURAL MEMBERS, PIPING, LIGHTS, CONDUITS, ELECTRICAL EQUIPMENT, AND BUILDING COMPONENTS. IN PREPARING THESE SHOP DRAWINGS, ESTABLISH LINES AND LEVELS FOR ALL DIVISIONS OF THE WORK IN THE AFFECTED AREA. IMMEDIATELY CALL TO THE ATTENTION OF THE ARCHITECT ANY INTERFERENCE OR CONFLICT FOR CLARIFICATION IN WRITING.
 SUBMIT SHOP DRAWINGS FOR ALL DUCTWORK.
 SUBMIT LAYOUT DRAWINGS OF EACH MECHANICAL SYSTEM SHOWING THE LOCATION, ARRANGEMENT, ETC. OF ALL EQUIPMENT, ALL TRADES, ETC. TO BE INSTALLED RELATED TO THE

RESPECTIVE SYSTEM.

15. AS-BUILT DRAWINGS:
 MAINTAIN DAILY UPDATED DRAWINGS SHOWING DEVIATIONS FROM CONSTRUCTION DOCUMENTS. AT THE END OF THE PROJECT, PROFESSIONALLY PREPARE AS-BUILT DRAWINGS AND SUBMIT THREE COPIES, ONE REPRODUCIBLE.

16. OPERATION AND MAINTENANCE MANUALS:
 UPON COMPLETION OF THE PROJECT, SUBMIT THREE COPIES OF ALL OPERATION AND MAINTENANCE MANUALS, WARRANTIES, SPARE PARTS LIST, AS-BUILT DRAWINGS, TEST AND BALANCE REPORTS, AND LETTER OF GUARANTEE ALL BOUND IN THREE RING BINDERS, CLEARLY SHOWING WHICH EQUIPMENT WAS SUPPLIED TO THE JOB.

17. PROJECT COMPLETION:
 BEFORE STARTING AND TESTING ANY SYSTEM, HVAC, OR PLUMBING, TO PREVENT INADVERTENT OPERATION OF THE MECHANICAL EQUIPMENT BEFORE THE MANUFACTURER'S INSPECTION AND TESTING, THE CONTRACTOR SHALL:
 VERIFY THAT ALL ELECTRICAL POWER IS OFF TO ALL MECHANICAL EQUIPMENT, INCLUDING THE AHU'S, ACCU'S, BOOSTER PUMPS, FIRE PUMPS, ETC.
 LOCK OUT EACH SYSTEM USING SETON MODEL NUMBER 70329; "DO NOT OPERATE" LOCK ON LOCKOUT TAGS, OR EQUIVALENT. INSTALL LOCKOUT TAGS AT EACH PIECE OF EQUIPMENT, ELECTRICAL DISCONNECTS, STARTERS, SWITCHES, ETC.
 REMOVE THESE TAGS ONLY WHEN THE MANUFACTURER APPROVES OF THE EQUIPMENT INSTALLATION IN WRITING.
 EACH MANUFACTURER OR THEIR REPRESENTATIVE SHALL INSPECT THEIR EQUIPMENT FOR COMPLIANCE TO THEIR INSTALLATION REQUIREMENTS AND RECOMMENDATIONS.
 IN ADDITION, THE COMPRESSOR MANUFACTURER SHALL INSPECT EACH REFRIGERANT PIPING INSTALLATION FOR ADHERENCE TO THE APPROVED REFRIGERANT PIPING DIAGRAMS, ROUTING.
 EACH MANUFACTURER SHALL PREPARE A PUNCH LIST OF ALL DEFICIENCIES, IN WRITING WITH COPIES TO THE ARCHITECT AND CONTRACTOR.
 EACH MANUFACTURER SHALL REINSPECT THE EQUIPMENT AFTER THE CONTRACTOR HAS CORRECTED ALL DEFICIENCIES.
 WHEN THE MANUFACTURER HAS GIVEN THEIR WRITTEN APPROVAL WITH COPIES TO THE ARCHITECT AND CONTRACTOR, THE CONTRACTOR MAY REMOVE THE LOCKOUT TAGS, SAFELY START, AND TEST THE EQUIPMENT, AS REQUIRED HEREIN.
 CONTRACTOR SHALL PROVIDE FOR ALL NECESSARY DRILLING OF WALL STUDS, CEILING JOISTS, PLATES, FINISHES, ETC. TO ACCOMMODATE ROUTING AND INSTALLATION OF ALL PIPING, DUCT, ETC.
 HVAC EQUIPMENT, METHODS AND MATERIALS

18. DUCTWORK GENERAL:
 DUCT SIZES SHOWN ON THE DRAWINGS ARE INSIDE DIMENSIONS AND DO NOT TAKE INTO ACCOUNT LINING THICKNESS. DUCTWORK SHALL BE GALVANIZED SHEET METAL WITH GAUGES, CONSTRUCTION DETAILS AND INSTALLATION ACCORDING TO N.F.P.A. STANDARD 90A, ASHRAE, AND SMACNA DUCT CONSTRUCTION MANUALS AND REQUIREMENTS.
 PROVIDE FLEXIBLE CONNECTIONS AT AIR HANDLING UNITS AND FANS. PROVIDE SINGLE THICKNESS TURNING VANES IN ELBOWS.
 PAINT DUCTS, SLEEVES, PLENUMS, ETC., INTERIORS VISIBLE THROUGH AIR DEVICES WITH A MINIMUM OF ONE COAT OF PROPER TYPE RUST PREVENTATIVE PRIMER, SUITABLE FOR GALVANIZED STEEL, AND TWO FINISH COATS OF FLAT BLACK PAINT.

19. DUCT CONSTRUCTION MATERIALS:
 RECTANGULAR SUPPLY, RETURN, OUTSIDE AIR, AND EXHAUST: LINED GALVANIZED SHEET METAL.
 ROUND DUCT AND RUN-OUTS: EXTERNALLY INSULATED GALVANIZED SHEET METAL DUCTS WITH SPIRAL LOCK SEAMS.
 FLEXIBLE DUCT: PRE-INSULATED FLEXIBLE DUCT. NO FLEXIBLE DUCT RUNS LONGER THAN 5 FEET. PROVIDE DRYER VENT PIPING INSTALLED AS REQUIRED BY THE MANUFACTURER AND PER CODE USING 4 INCH ROUND GALVANIZED STEEL, SEALED AND SUPPORTED. THE USE OF FLEXIBLE DRYER VENT PIPE IS PROHIBITED.

20. FABRICATION, ERECTION, AND SUPPORT:
 ALL DUCTWORK SHALL BE FABRICATED, ERECTED, BRACED, AND SUPPORTED IN STRICT ACCORDANCE WITH THE LATEST EDITIONS OF SMACNA AND ASHRAE REQUIREMENTS.

21. ACOUSTIC LINED DUCTWORK:
 ACOUSTICALLY AND THERMALLY LINE 10' OF RECTANGULAR SUPPLY, RETURN, OUTSIDE AIR, AND EXHAUST DUCT AND PLENUMS WITH 1" THICK, 1 1/2 PCF FIBERGLASS DUCT LINER, APPLIED PER THE MANUFACTURER'S AND NAIMA REQUIREMENTS. DUCT LINER SHALL MEET AND/OR EXCEED ASHRAE'S I.A.Q. STANDARD 62. USE WELDED STICK CLIPS, IN LIEU OF ADHESIVE TYPE FASTENERS AND FULL COVERAGE ADHESIVE. PROVIDE EDGE NOSINGS WHERE REQUIRED. COAT ALL EXPOSED FIBERGLASS WITH HARDCAST "LAG-GRIP 671".

22. JOINT SEALING:
 SEAL ALL DUCT JOINTS AND SEAMS (LONGITUDINAL AND TRANSVERSE) WITH HIGH PRESSURE DUCT SEALER, HARDCAST "IRON-GRIP 601" OR APPROVED EQUIVALENT. REINFORCED FOIL BACKED TAPES, CLOTH OR PLASTIC BACKED TAPES (DUCT TAPE) ARE NOT ACCEPTABLE.

23. FLEXIBLE AIR DUCT:
 DUCT SHALL BE UL LISTED UL-181, CLASS I AIR DUCT MATERIAL AND SHALL COMPLY WITH N.F.P.A 90A AND 90B AND ALL LOCAL REQUIREMENTS. DUCT SHALL HAVE AN OPERATING AIR PRESSURE OF 6 INCHES WG POSITIVE AND 4 INCHES WG NEGATIVE, ACOUSTICAL DOUBLE LAMINATED INNER FABRIC BONDED TO A STEEL HELIX WIRE. OUTER JACKET FIRE RETARDANT REINFORCED ALUMINUM MYLAR WITH FIBERGLASS INSULATION. FLEXMASTER TYPE "8M" ACOUSTICAL INSULATED OR EQUIVALENT.
 MAKE ALL FLEXIBLE DUCT CONNECTIONS TO HARD DUCT USING STAINLESS STEEL SCREW CLAMPING BANDS AND SEALED AIR TIGHT WITH HIGH PRESSURE DUCT SEALER. PLASTIC BANDS ARE NOT ACCEPTABLE.
 SEAL FLEXIBLE DUCT VAPOR BARRIER TO HARD DUCT AND/OR ADJACENT INSULATION. NO EXPOSED FIBERGLASS SHALL BE VISIBLE.

24. AIR DISTRIBUTION DEVICES:
 COORDINATE THE EXACT LOCATIONS OF ALL AIR DEVICE NEEDS WITH THE ARCHITECTURAL DRAWINGS PRIOR TO INSTALLATION. COORDINATE THE EXACT LOCATION OF EACH OUTLET WITH THE ARCHITECT WITH REGARD TO CEILING AND WALL SPACING, CENTERING ALONG SOFFITS, WALLS, ETC.
 FURNISH AND INSTALL WHERE SHOWN ON THE DRAWINGS ALL DIFFUSERS, GRILLES, AND REGISTERS OF THE SIZE, TYPE, AND CAPACITY AS INDICATED IN THE AIR DEVICE SCHEDULE.
 ELBOWS:
 25. TURNING VANES AND SMOOTH RADIUS ELBOW (WITHOUT VANES):
 AT ALL DUCT TURNS OF 45 DEGREES OR MORE, PROVIDE SINGLE THICKNESS TURNING VANES PER SMACNA REQUIREMENTS. ALTERNATIVELY, USE SMOOTH RADIUS ELBOW (R/W = 1.5).
 26. BRANCH TAKEOFF FITTINGS:
 AT ALL MAIN TO BRANCH DUCT TAPS, TAKEOFFS, OR RUN-OUTS, PROVIDE 45 DEGREE ENTRANCE TAPS, AS DETAILED BY SMACNA STANDARDS.

DATE:	05/28/2019
COMM No:	19-01
DRAWN BY:	GTL
CHECKED BY:	JNB
STATE PROJECT No:	

MECHANICAL SPECIFICATIONS

MOOG, INC FACILITY AT 1213 NORTH MAIN STREET BLACKSBURG, VA 24080
 MECHANICAL AND RESTROOM RENOVATIONS

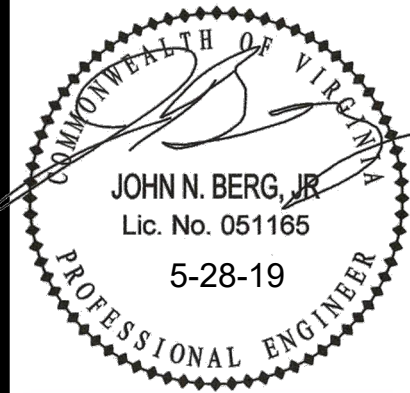

5 Design, LLC
 P.O. Box 320
 Riner, VA 24149
 540-230-2619
 www.5designarchitecture.com

REVISIONS	DESCRIPTION	DATE
		No.

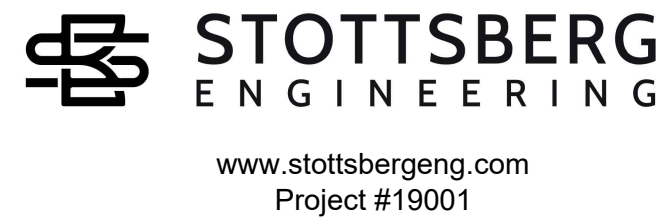

M004

www.stottsbergeng.com
 Project #19001

27. DUCT MOUNTED ACCESS PANELS:
 INSTALL ACCESS PANELS AS FOLLOWS:
 AT INLET OF EACH DUCT MOUNTED FIRE AND MOTORIZED DAMPER.
 FOR DUCT MOUNTED CONTROLS.
 AS REQUIRED AND DIRECTED BY THE TEST AND BALANCE CONTRACTOR.
 WHERE REQUIRED FOR DUCT INSPECTION, MAINTENANCE, AND CLEANING.
 ACCESS PANELS SHALL BE 18 INCHES X 18 INCHES OR LARGEST DUCT WILL ALLOW. NORMALLY CENTER THE ACCESS PANEL IN THE BOTTOM OF THE DUCT AS CLOSE AS POSSIBLE TO THE DUCT MOUNTED DEVICE. ACCESS PANELS MAY BE INSTALLED ON THE SIDE OF THE DUCT, WHERE NECESSARY.
 ACCESS PANELS SHALL BE DOUBLE WALL INSULATED HINGED WITH NEOPRENE GASKETS AND CAM LOCKS ON EACH UNHINGED SIDE. WHERE REQUIRED BECAUSE OF PANEL OPENING CLEARANCE, SUBSTITUTE UNHINGED ACCESS PANELS WITH CAM LOCKS ON EACH SIDE AND CAPTIVE CHAIN. ACCESS PANELS SHALL BE FLEXMASTER "TBSM-TAB DOOR" GREENHECK MODEL "HAD-10", OR EQUIVALENT.
 28. REFRIGERANT PIPING:
 REFRIGERANT PIPING SHALL CONFORM TO THE REQUIREMENTS OF THE SAFETY CODES FOR MECHANICAL REFRIGERATION AND REFRIGERANT PIPING AND THE MANUFACTURER REQUIREMENTS.
 RUN ALL PIPING SQUARE TO BUILDING LINES WHEREVER POSSIBLE. FIELD ROUTE PIPING IN ORDER TO PROVIDE FOR EASE OF ACCESS TO VALVES AND OTHER APPURTENANCES.
 SUPPORT INTERIOR PIPING FROM THE BUILDING STRUCTURE USING COPPER OR PVC COATED HANGERS. SUPPORT REFRIGERANT PIPING 4 FOOT ON CENTER AND AT EACH CHANGE OF DIRECTION. PROVIDE 4" WIDE INSULATION SADDLES.
 SUBMIT REFRIGERANT PIPING LAYOUT SHOP DRAWINGS FOR EACH UNIQUE SYSTEM, REVIEWED AND APPROVED BY THE MANUFACTURER, IN WRITING. SHOW ALL FILTERS, DRIERS, SIGHT-GLASSES, VALVES, ETC. AS REQUIRED BY THE MANUFACTURER.
 USE REFRIGERANT GRADE, TYPE "K" HARD DRAWN COPPER PIPE WITH LONG RADIUS ELBOWS. NO CAST FITTINGS ARE ACCEPTABLE.
 INSTALL FILTER DRIER EQUIVALENT TO SPORLAN CATCH-ALL.
 INSTALL SIGHT GLASSES WITH MOISTURE INDICATORS COVERED BY A PROTECTIVE CAP. LOCATE THE SIGHT GLASSES INSIDE THE BUILDINGS, CLOSE TO THE FAN COIL IN THEIR RESPECTIVE MECHANICAL CLOSETS.
 PROVIDE EXTERNAL FRONT SEATED BRASS SERVICE VALVES WITH SWEAT CONNECTIONS, WITH SERVICE PORTS FOR CHECKING OPERATING REFRIGERANT PRESSURES.
 COPPER SHALL BE CLEANED AND SHINED BEFORE BRAZING. BRAZE USING J.W. HARRIS "DYNAFLOW" 6% SILVER BRAZING ALLOY.
 PIPING SHALL BE PURGED WITH DRY NITROGEN WHILE BRAZING TO PREVENT OXIDATION. UPON COMPLETION OF A WELD, THE WELD SHALL BE WIPED WITH A DAMP RAG TO REMOVE FLUX WHILE STILL HOT.
 ALL PIPING SHALL BE TESTED FOR 24 HOURS IN ACCORDANCE WITH THE FOLLOWING SCHEDULE AND PROVEN TIGHT:
 DISCHARGE AND LIQUID REFRIGERANT PIPING--300 PSIG, NITROGEN.
 SUCTION REFRIGERANT PIPING--150 PSIG NITROGEN.
 REFRIGERANT PIPING, AFTER PROVEN TIGHT, SHALL BE EVACUATED BY MEANS OF AN APPROVED VACUUM PUMP TO A VACUUM OF 2.5 MM HG ABSOLUTE. SYSTEMS SHALL STAND UNDER VACUUM WITH VACUUM PUMP OFF FOR A MINIMUM OF 12 HOURS. SYSTEMS MAY BE CHARGED WITH PROPER REFRIGERANT AFTER ARCHITECT'S APPROVAL OF VACUUM TEST. A DEHYDRATOR SHALL BE USED IN CHARGING HOSE DURING CHARGING OF SYSTEMS WITH REFRIGERANT.
 29. GENERAL
 THIS SECTION APPLIES TO ALL MECHANICAL WORK.
 ALL INSULATION SHALL BE IN STRICT ACCORDANCE WITH ASHRAE STANDARDS AND ALL LOCAL AND STATE ENERGY CODES.
 THE INSULATION WORK SHALL BE PERFORMED BY A FIRM REGULARLY ENGAGED IN THIS TYPE WORK USING MECHANICS SKILLED IN THE TRADE.
 INSTALL ALL MATERIALS AS RECOMMENDED BY THE MANUFACTURER FOR THE SERVICE INTENDED. ALL INSULATION MATERIAL, INCLUDING SEALER MATERIAL, ADHESIVES, COVERING MATERIAL, FINISH, ETC. SHALL HAVE A U.L. LISTED FLAME SPREAD RATING NOT OVER 24 WITHOUT EVIDENCE OF CONTINUED PROGRESSIVE COMBUSTION AND WITH A SMOKE DEVELOPED RATING NOT HIGHER THAN 50. ALL COATINGS AND COVERINGS FOR HOT SERVICE SHALL BE BREATHER TYPE AND VAPOR BARRIER TYPE FOR COLD SERVICE.
 HVAC PIPING:
 INSULATE REFRIGERANT SUCTION LINES AND ALL CONDENSATE DRAIN LINES WITH 1" THICK CLOSE CELLED ELASTOMERIC INSULATION INSTALLED PER THE MANUFACTURERS REQUIREMENTS.
 PAINT EXTERIOR INSULATION WITH TWO COATS OF PAINT AS REQUIRED BY THE INSULATION MANUFACTURER.
 EXTERNALLY INSULATED DUCTS:
 EXTERNALLY INSULATE ALL ROUND SUPPLY, RETURN, OUTSIDE AIR, AND EXHAUST DUCTWORK WITH 1 1/2" THICK (3/4 LBS/CU. FT. DENSITY) DUCT WRAP WITH ALUMINUM ALL SERVICE JACKET, VAPOR BARRIER, EXCEPT PRE-INSULATED FLEXIBLE DUCT.
 30. EQUIPMENT:
 CAPACITY, PERFORMANCE AND CHARACTERISTICS OF EQUIPMENT SHALL BE AS INDICATED ON THE DRAWINGS AND AS SPECIFIED OR IMPLIED HEREIN. CONTRACTOR SHALL BE RESPONSIBLE FOR ANY INCREASED COST TO HIMSELF OR OTHERS FOR EQUIPMENT WHICH DEVIATES FROM THAT SCHEDULED OR IMPLIED HEREIN. REGARDLESS OF COST AFFECT, THE ARCHITECT MUST APPROVE ANY DEVIATION FROM THE DRAWINGS AND THE SPECIFICATION.
 31. MOTORS AND STARTERS:
 ALL ELECTRIC MOTORS SHALL BE HIGH EFFICIENCY TYPE WITH MAXIMUM OF 1750 RPM WITH OPEN DRIP PROOF OR TEFC ENCLOSURES, UNLESS OTHERWISE NOTED. MOTORS LOCATED ON AIR HANDLING UNITS SHALL BE MOUNTED IN RUBBER SUPPORTS OR THE FAN SHALL BE INDEPENDENTLY SUPPORTED ON SPRING ISOLATORS. MOTORS LOCATED IN THE CONDITIONED SPACE SHALL BE SELECTED FOR QUIET OPERATION AND SHALL NOT PRODUCE AN OBJECTIONABLE "MOTOR NOISE" IN THE SPACE.
 ELECTRICAL CHARACTERISTICS SHALL BE VERIFIED FROM THE ELECTRICAL DRAWINGS, PRIOR TO BIDDING, AND VERIFIED ON THE JOB WITH THE ELECTRICAL SUB-CONTRACTOR. IF A CONFLICT ARISES, THE ELECTRICAL DRAWINGS SHALL BE THE AUTHORITY.
 PROVIDE MOTOR STARTERS AND PROPER HEATER ELEMENTS SIZED IN ACCORDANCE WITH NFPA 70. STARTERS SHALL BE SQUARE-D OR EQUIVALENT WITH OVERLOAD TRIP ELEMENT IN EACH PHASE. LARGER MOTORS AND THEIR STARTERS SHALL MEET THE REQUIREMENTS OF THE UTILITY COMPANY AS TO INRUSH ALLOWABLE AND THE TYPE OF STARTING PERMITTED.
 SHOULD ANY MECHANICAL EQUIPMENT REQUIRE EXTRA WORK BY OTHER TRADES, FOR PROPER INSTALLATION, THIS CONTRACTOR SHALL BEAR ALL COSTS, SUCH AS INCREASED ELECTRICAL, STRUCTURAL, ROOFING, ETC.

32. SYSTEMS TEST AND BALANCE:
 THE REQUIRED TEST & BALANCE OF THE HVAC SYSTEM SHALL BE PERFORMED BY AN APPROVED INDEPENDENT TESTING AGENCY AS SPECIFIED BELOW.
 AGENCY QUALIFICATIONS:
 TEST & BALANCE AGENCY (TBA) SHALL BE PERFORMED BY AN INDEPENDENT AGENCY ENGAGED SOLELY IN TEST AND BALANCE WORK. AGENCY SHALL BE A MEMBER OF THE ASSOCIATED AIR BALANCE COUNCIL (AABC) AND NATIONAL ENVIRONMENTAL BALANCING BUREAU, (NEBB).
 SUBMIT A WRITTEN REPORT WITHIN 30 DAYS OF COMMENCING WORK, WITH ANY RECOMMENDED CHANGES TO INSURE BALANCING CAPABILITY.
 SUBMIT A DETAILED TEST PLAN TO THE ARCHITECT ILLUSTRATING ALL FORMATS, DRAWINGS, AND TEST PROCEDURE TO BE USED FOR TESTING THE COMPLETED SYSTEM. THE APPROVED PLAN WILL BE USED FOR TESTING THE SYSTEMS.
 PROCEDURES SHALL INCLUDE REQUIREMENTS LISTED IN AABC/NEBB STANDARDS, LATEST EDITION AND ANY SPECIAL REQUIREMENTS FOR THIS PROJECT.
 MAKE PROJECT VISITS AS REQUIRED DURING CONSTRUCTION PERIOD INSPECTING FOR PROPER INSTALLATION OF THE SYSTEM AND RELATED BALANCING DEVICES. PROJECT VISIT REPORTS SHALL BE MADE TO THE ARCHITECT IN WRITING.
 CONTRACTORS REQUIREMENTS PRIOR TO TEST & BALANCE:
 THE CONTRACTOR SHALL PERFORM ALL REQUIRED PRELIMINARY TESTS AND OTHER PREPARATORY WORK, INCLUDING BUT NOT LIMITED TO:
 MAKE SURE ALL FANS ARE OPERATING. CHECK ROTATION, RPM, AND AMPS.
 CHECK ALL DAMPERS FOR OPERATION.
 PUT ALL HVAC EQUIPMENT IN FULL OPERATION INCLUDING AIR UNITS, ACCU'S AND FANS. MAKE SURE ALL HVAC CONTROLS ARE INSTALLED AND FULLY OPERATIONAL. CLEAN/REPLACE FILTERS JUST PRIOR TO TESTING.
 PROVIDE ALL BALANCING DEVICES AND DRIVE CHANGES THAT ARE DEEMED NECESSARY BY T&B AGENCY FOR BALANCE AT NO ADDITIONAL COST TO THE OWNER.
 TEST & BALANCE AGENCY SHALL BALANCE ALL AIR SYSTEMS FOR OPERATION WITHIN DESIGN CRITERIA. PRIME MOVERS SHALL BE WITHIN 5% OF DESIGN AND TERMINALS WITHIN 10% OF DESIGN.
 AIR SYSTEMS SHALL BE BALANCED AS DESCRIBED HEREIN.
 TEST REPORT:
 THE TBA SHALL PREPARE FIVE (5) COPIES OF A FINAL COMPREHENSIVE TEST REPORT IN THE FOLLOWING FORMAT.
 REPORT SHALL BE BOUND 8-1/2 X 11" WITH SUBSTANTIAL COVERS USING APPROVED FORMS. TYPED OR COMPUTER GENERATED REPORTS ARE ACCEPTABLE.
 REPORT SHALL BE INDEXED.
 TABLE OF CONTENTS SHALL LIST ALL REPORTS.
 ALL AIR OUTLETS SHALL BE LOCATED ON CODED DRAWINGS PREPARED BY THE T&B AGENCY. AIR OUTLETS FORMS SHALL BE PREPARED AND CORRELATED TO THE CODED DRAWINGS.
 TEST SUMMARY SHALL DESCRIBE FINAL TEST PROCEDURES AND SPECIAL CONDITIONS DURING TESTS (SUCH AS THERMOSTAT OUTSIDE/RETURN AIR RELATIONSHIP), AND DUCT STATIC PRESSURE.
 DESCRIBE OTHER DATA THAT MAY ASSIST OPERATING PERSONNEL IN THE CONTINUING OPERATION OF THE SYSTEM.
 T&B CONTRACTOR SHALL TAKE AND RECORD ALL NECESSARY READINGS AT THE FINAL BALANCE POINTS, SUCH AS BUT NOT LIMITED TO: AIR QUANTITIES, PRESSURES, SETPOINTS, ENTERING AND LEAVING COIL TEMPERATURES, SPACE INDOOR AND OUTSIDE WET AND DRY BULB TEMPERATURES, OUTDOOR WEATHER CONDITIONS, ELECTRICAL READINGS OF ALL NEW AND EXISTING MOTORS, COMPRESSORS, ETC.
 TEST REPORT SHALL CONTAIN TBA CERTIFICATION OF TEST DATA AND SYSTEM CONDITIONS. SUBMIT THE TEST REPORTS, FOR REVIEW, BEFORE SUBSTANTIAL COMPLETION.
 32. CONTROLS:
 ALL CONTROLS FOR THE NEW MECHANICAL SYSTEMS WILL BE PROVIDED BY THE OWNER UNDER A SEPARATE CONTRACT. ALL CONTROL INSTALLATION AND WIRING SHALL BE PROVIDED BY CONTRACTOR PER OWNERS SPECIFICATIONS (TYPICAL).

END OF MECHANICAL SPECIFICATIONS.



DATE:	05/28/2019
COMM No:	19-01
DRAWN BY:	GTL
CHECKED BY:	JNB
STATE PROJECT No:	

MECHANICAL SPECIFICATIONS

MOOG, INC FACILITY AT 1213 NORTH MAIN STREET BLACKSBURG, VA 24060
 MECHANICAL AND RESTROOM RENOVATIONS

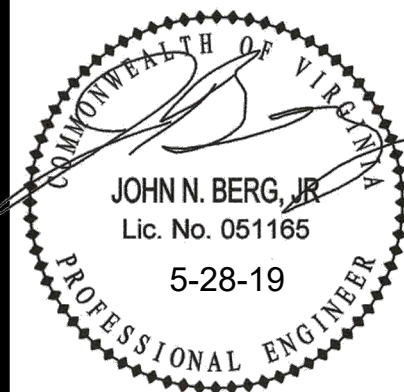

5 Design, LLC
 P.O. Box 320
 Riner, VA 24149
 540-230-2619
 www.5designarchitecture.com

REVISIONS	DATE	DESCRIPTION
No. 1	5-29-19	OWNER REVIEW



www.stottsbergeng.com
 Project #19001

M005

**MECHANICAL DEMOLITION
 PARTIAL FIRST FLOOR PLAN**

MOOG, INC FACILITY AT 1213 NORTH MAIN STREET BLACKSBURG, VA 24060
 MECHANICAL AND RESTROOM RENOVATIONS

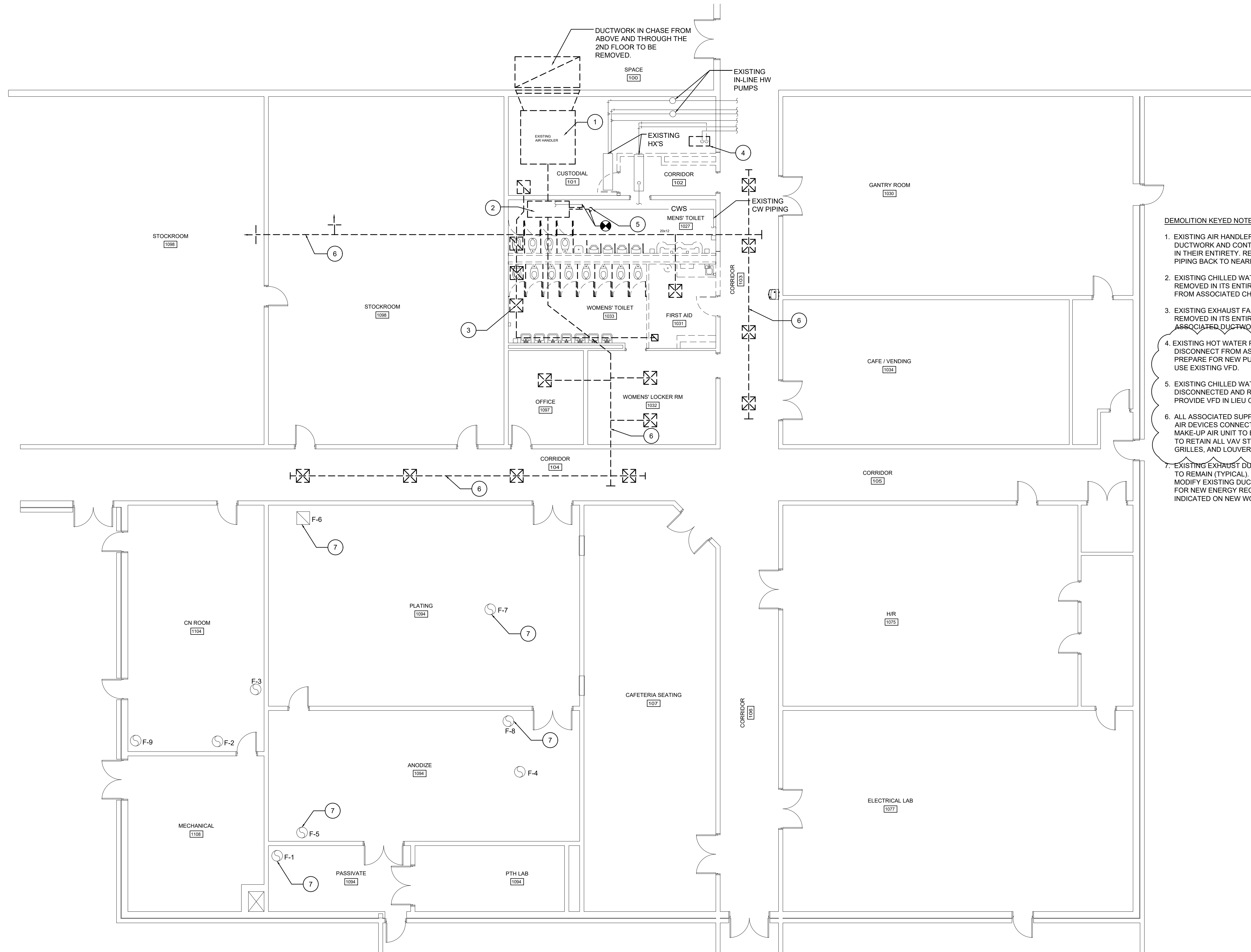

- DEMOLITION KEYED NOTES:**
- EXISTING AIR HANDLER AND ASSOCIATED DUCTWORK AND CONTROLS TO BE REMOVED IN THEIR ENTIRETY. REMOVE ALL STEAM PIPING BACK TO NEAREST MAIN AND CAP.
 - EXISTING CHILLED WATER COIL TO BE REMOVED IN ITS ENTIRETY. DISCONNECT FROM ASSOCIATED CHILLED WATER PIPING.
 - EXISTING EXHAUST FAN ON ROOF TO BE REMOVED IN ITS ENTIRETY ALONG WITH ASSOCIATED DUCTWORK AND AIR DEVICES.
 - EXISTING HOT WATER PUMP TO BE REMOVED. DISCONNECT FROM ASSOCIATED PIPING AND PREPARE FOR NEW PUMP. NEW PUMP SHALL USE EXISTING VFD.
 - EXISTING CHILLED WATER PUMP TO BE DISCONNECTED AND RE-USED. OWNER SHALL PROVIDE VFD IN LIEU OF STARTER.
 - ALL ASSOCIATED SUPPLY AIR DUCTWORK AND AIR DEVICES CONNECTED TO EXISTING MAKE-UP AIR UNIT TO BE REMOVED. OWNER TO RETAIN ALL VAV STYLE DIFFUSERS, GRILLES, AND LOUVERS.
 - EXISTING EXHAUST DUCT UP TO FAN ON ROOF TO REMAIN (TYPICAL). CONTRACTOR SHALL MODIFY EXISTING DUCTWORK AS REQUIRED FOR NEW ENERGY RECOVERY COIL WHERE INDICATED ON NEW WORK PLANS.

PARTIAL PLAN OF DEMOLITION

1/8" = 1'-0"
 1/8" = 1'-0"

**STOTTSBERG
 ENGINEERING**
 www.stottsbergeng.com
 Project #19001



5 Design, LLC
 P.O. Box 320
 Riner, VA 24149
 540-230-2619
 www.5designarchitecture.com

REVISIONS	No.	DESCRIPTION	DATE
	1	OWNER REVIEW	5-29-19

M100

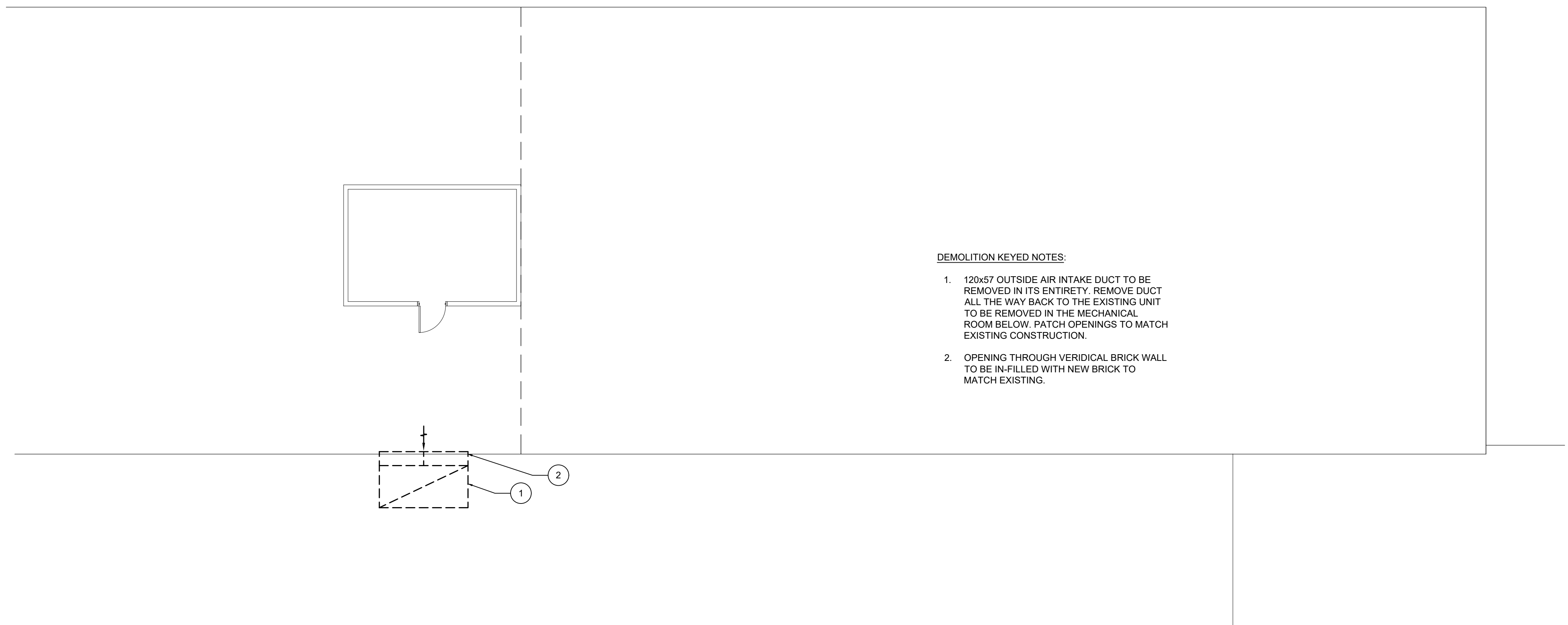

DEMOLITION KEYED NOTES:

1. 120x57 OUTSIDE AIR INTAKE DUCT TO BE REMOVED IN ITS ENTIRETY. REMOVE DUCT ALL THE WAY BACK TO THE EXISTING UNIT TO BE REMOVED IN THE MECHANICAL ROOM BELOW. PATCH OPENINGS TO MATCH EXISTING CONSTRUCTION.
2. OPENING THROUGH VERIDICAL BRICK WALL TO BE IN-FILLED WITH NEW BRICK TO MATCH EXISTING.

PARTIAL MECHANICAL ROOF / 3RD FLOOR DEMOLITION PLAN

1/8" = 1'-0"
 1/8" = 1'-0" 8 0 8 16

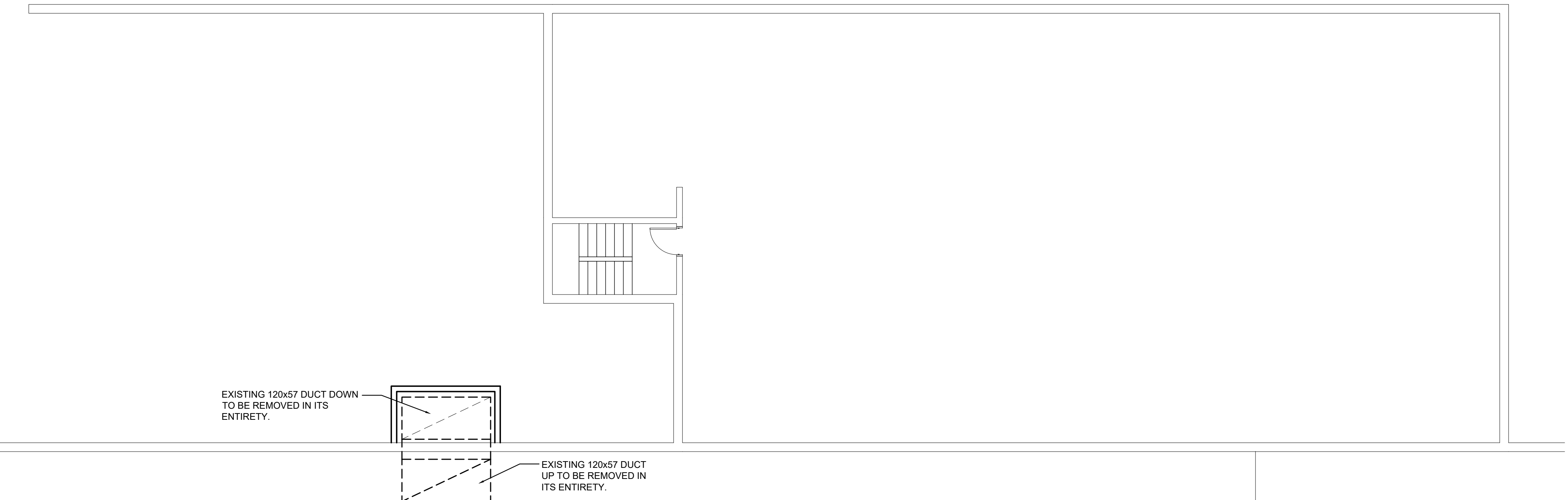

EXISTING 120x57 DUCT DOWN TO BE REMOVED IN ITS ENTIRETY.

EXISTING 120x57 DUCT UP TO BE REMOVED IN ITS ENTIRETY.

PARTIAL MECHANICAL ROOF / 2ND FLOOR DEMOLITION PLAN

1/8" = 1'-0"
 1/8" = 1'-0" 8 0 8 16

STOTTSBERG ENGINEERING
 www.stottsbergeng.com
 Project #19001

DATE:	05/28/2019
COMM No:	19-01
DRAWN BY:	GTL
CHECKED BY:	JNB
STATE PROJECT No:	

**MECHANICAL DEMOLITION
 PARTIAL ROOF PLAN**

MOOG, INC FACILITY AT 1213 NORTH MAIN STREET BLACKSBURG, VA 24060
 MECHANICAL AND RESTROOM RENOVATIONS

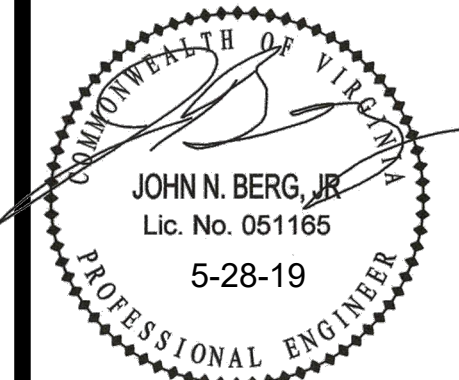

5 Design, LLC
 P.O. Box 320
 Riner, VA 24149
 540-230-2619
 www.5designarchitecture.com

REVISIONS	DESCRIPTION	DATE
No.	<	<
	<	<
	<	<

M101

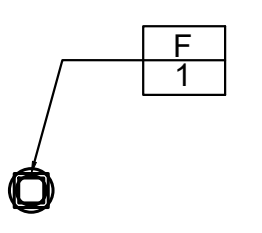
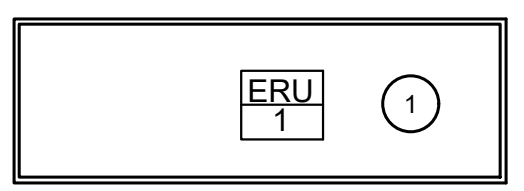
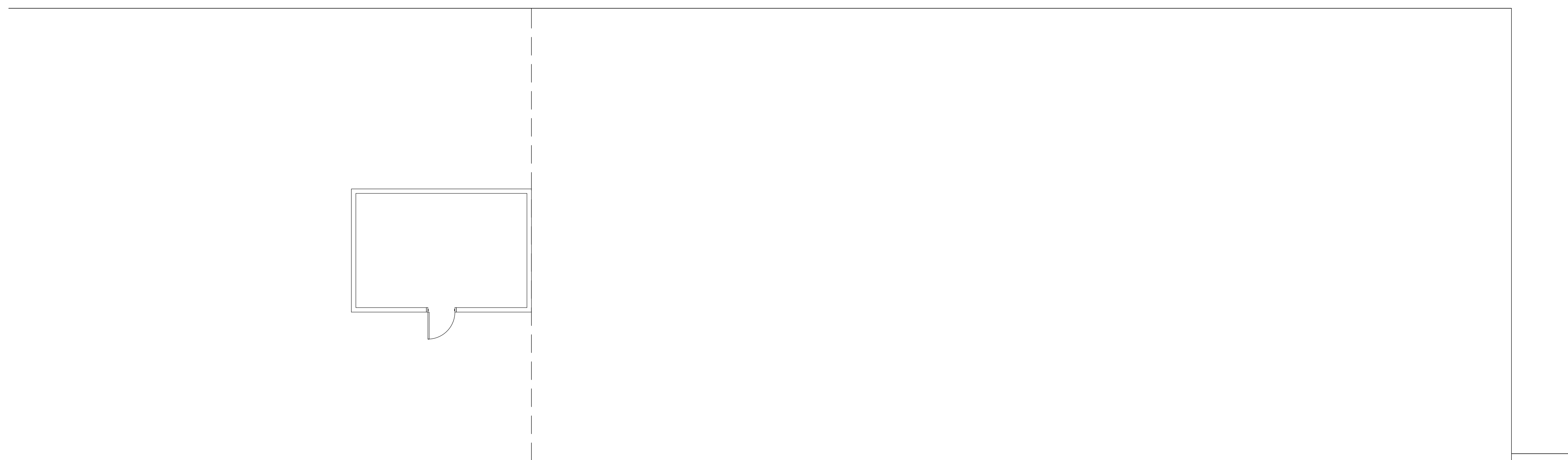

NEW WORK KEYED NOTES:
 1. ROUTE CONDENSATE DRAIN FROM UNIT DRAIN TO NEAREST ROOF DRAIN.

PARTIAL MECHANICAL ROOF PLAN

1/8" = 1'-0"

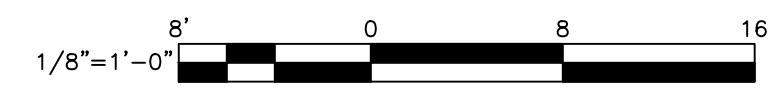

STOTTSBERG ENGINEERING
 www.stottsbergeng.com
 Project #19001

DATE:	05/28/2019
COMM No:	19-01
DRAWN BY:	GTL
CHECKED BY:	JNB
STATE PROJECT No:	

**MECHANICAL NEW WORK
 PARTIAL ROOF PLAN**

MOOG, INC FACILITY AT 1213 NORTH MAIN STREET BLACKSBURG, VA 24060
 MECHANICAL AND RESTROOM RENOVATIONS

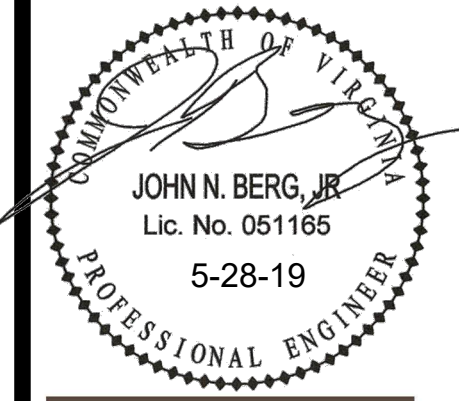

5 Design, LLC
 P.O. Box 320
 Riner, VA 24149
 540-230-2619
 www.5designarchitecture.com

REVISIONS	DESCRIPTION	DATE
No.	Δ	Δ
	Δ	Δ
	Δ	Δ
	Δ	Δ

M201